

OPERATION/SERVICE MANUAL
for
MCC XCELSIOR SERIES

T-367

REV. 02/2015



TABLE OF CONTENTS

SAFETY SUMMARY **Safety-1**

DESCRIPTION **1-1**

1.1 INTRODUCTION 1-1

1.2 GENERAL DESCRIPTION 1-2

 1.2.1 Rooftop Unit 1-2

 1.2.2 Condensing Section 1-2

 1.2.3 Evaporator Sections 1-3

 1.2.4 MCC Microprocessor 1-3

1.3 REFRIGERATION SYSTEM COMPONENT SPECIFICATIONS 1-3

1.4 ELECTRICAL SPECIFICATIONS - MOTORS 1-3

1.5 SAFETY DEVICES 1-4

1.6 AIR CONDITIONING REFRIGERATION CYCLE 1-5

1.7 HEATING CYCLE 1-5

OPERATION of MCC XCELSIOR DRIVER DISPLAY **2-1**

2.1 General Description 2-1

2.2 STARTING, STOPPING AND OPERATING INSTRUCTIONS 2-1

 2.2.1 Starting 2-1

2.3 SEQUENCE OF OPERATION 2-2

 2.3.1 Function of Keys when “Engine On” and controller active: 2-2

2.4 BASIC OPERATING INSTRUCTIONS 2-3

 2.4.1 Display 2-3

 2.4.2 Interior Set Point Temperature Control 2-3

 2.4.3 Blower Speed Setting 2-3

 2.4.4 Mode Selection Descriptions 2-3

 2.4.5 Capacity Control “Ladder” Diagrams 2-3

 2.4.6 Display Settings 2-5

 2.4.7 HVAC Information Screens 2-6

 2.4.8 HVAC Diagnostics Screens 2-7

 2.4.9 HVAC Alarm Description 2-8

2.5 MCC Eco NG Coolview 2-9

 2.5.1 Starting the MCC Coolview Application 2-10

 2.5.2 Coolview Screen Layout 2-11

 2.5.3 Eco NG Display Pin out Description 2-16

 2.5.4 Eco NG Controller Pin out Description 2-17

TROUBLESHOOTING **3-1**

3.1 System Will Not Cool 3-1

3.2 System Runs But Has Insufficient Cooling 3-1

3.3 Abnormal Pressures 3-1

3.4 Abnormal Noise Or Vibrations 3-1

3.5 No Evaporator Air Flow Or Restricted Air Flow 3-2

3.6 Expansion Valve Malfunction 3-2

3.7 Heating Malfunction 3-2

SERVICE **4-1**

4.1 MAINTENANCE SCHEDULE 4-1



4.2 OPENING TOP COVER (EVAPORATORS) 4-2

4.3 REMOVING TOP COVERS (CONDENSER) 4-2

4.4 SUCTION AND DISCHARGE SERVICE VALVES 4-3

 4.4.1 Installing R-134a Manifold Gauge Set 4-4

 4.4.2 SYSTEM PUMP DOWN FOR LOW SIDE REPAIR 4-6

 4.4.3. Removing Entire System Charge 4-7

4.5 REFRIGERANT LEAK CHECK 4-7

4.6 EVACUATION AND DEHYDRATION 4-7

 4.6.1 General 4-7

 4.6.2 Preparation 4-7

 4.6.3 Procedure for Evacuation and Dehydrating System (One Time Evacuation) 4-8

 4.6.4 Procedure for Evacuation and Dehydrating System (Triple Evacuation) 4-8

4.7 CHECKING AND ADDING REFRIGERANT TO SYSTEM 4-8

 4.7.1 Checking Refrigerant Charge By Pressures 4-8

 4-9

 4.7.2 Checking Refrigerant Charge By Receiver Sight Glasses 4-9

 4.7.3 Adding Full Charge 4-9

 4.7.4 Adding Partial Charge 4-11

4.8 CHECKING SYSTEM FOR NON-CONDENSIBLES 4-11

4.9 CHECKING AND REPLACING HIGH OR LOW PRESSURE SWITCH 4-11

4.10 FILTER-DRIER 4-12

 4.10.1 To Check Filter-Drier 4-12

 4.10.2 To Replace Filter-Drier 4-12

4.11 SERVICING THE LIQUID LINE SERVICE VALVE 4-12

 4.11.1 Coil Replacement 4-13

 4.11.2 Internal Part Replacement 4-13

 4.11.3 Replace Entire LLS Valve 4-13

4.12 THERMOSTATIC EXPANSION VALVE 4-14

 4.12.1 Valve Replacement 4-14

 4.12.2 Superheat Measurement 4-14

4.13 REPLACING EVAPORATOR RETURN AIR FILTERS 4-15

4.14 COMPRESSOR MAINTENANCE 4-16

 4.14.1 Shaft Seal Reservoir 4-16

 4.14.2 Refrigerant Removal From An Inoperative Compressor. 4-16

 4.14.3 Pump Down An Operable Compressor For Repair 4-16

 4.14.4 Removing the Compressor 4-17

 4.14.5 Transferring Compressor Clutch 4-18

 4.14.6 Compressor Oil Level 4-19

 4.14.7 Checking Unloader Operation 4-19

4.15 TEMPERATURE SENSOR CHECKOUT 4-21

4.16 PRESSURE TRANSDUCER CHECKOUT 4-21

4.17 REPLACING SENSORS AND TRANSDUCERS 4-21

ELECTRICAL 5-1

 5.1 INTRODUCTION 5-1



LIST OF TABLES

Table 1-1 50-2104 Models 1-1

Table 1-2 Additional Support Manuals 1-1

Table 3-1 General System Troubleshooting Procedures 3-1

Table 4-1 Temperature Sensor Resistance 4-21

Table 4-2 Pressure Transducer Voltage 4-22

Table 4-3 R-134a Temperature - Pressure Chart 4-23

LIST OF FIGURES

Figure 1-1 50-2104 Rooftop Unit (Xcelsior) 1-2

Figure 1-2 Refrigerant Flow Diagram 1-6

Figure 1-3 Heat Flow Diagram 1-7

Figure 2-1 Driver Display Module- Control Layout 2-1

Figure 2-2 Driver Display Module- Display Layout 2-2

Figure 2-3 Capacity Control Ladder Diagrams 2-4

Figure 2-4 HVAC DISPLAY SETTINGS 2-5

Figure 2-5 HVAC INFORMATION SCREENS 2-6

Figure 2-6 HVAC DIAGNOSTIC SCREENS 2-7

Figure 2-7 MCC Eco NG Display Alarms 2-8

Figure 2-8 MCC Eco NG Coolview (Example Screenshot) 2-9

Figure 2-9 MCC Eco NG Coolview (VIEW Tab) 2-10

Figure 2-10 MCC Eco NG Coolview Inputs and Mode (VIEW Tab) 2-11

Figure 2-11 MCC Eco NG Coolview Outputs (VIEW Tab) 2-12

Figure 2-12 MCC Eco NG Coolview Error List (ERROR Tab) 2-12

Figure 2-13 MCC Eco NG Coolview Statistics (HOURS Tab) 2-13

Figure 2-14 MCC Eco NG Coolview Simulation Mode 2-14

Figure 2-15 MCC Eco NG Coolview Data Logger 2-15

Figure 2-16 MCC Eco NG Display Pinout 2-16

Figure 2-17 MCC Eco NG Controller Pinout 2-17

Figure 4-1 Opening Top Cover (Evaporator) 4-2

Figure 4-2 Removing Top Covers (Condenser) 4-2

Figure 4-3 Suction or Discharge Service Valve 4-3

Figure 4-4 Manifold Gauge Set (R-134a) 4-4

Figure 4-5 Service Connections 4-5

Figure 4-6 Rule of Thumb 4-8

Figure 4-7 Service Connections 4-10

Figure 4-8 Checking High Pressure Switch 4-11

Figure 4-9 Filter-Drier Removal 4-12

Figure 4-10 Liquid Line Solenoid Valve 4-13

Figure 4-11 Thermostatic Expansion Valve Bulb and Thermocouple 4-14

Figure 4-12. Compressor Service Connections 4-16

Figure 4-13. Compressor Service Connections 4-16

Figure 4-14. Compressors 4-17



LIST OF FIGURES (Continued)

Figure 4-15. Removing Bypass Piston Plug	4-17
Figure 4-16. Compressor Clutch	4-18
Figure 4-17 Transducer Terminal Location	4-21
Figure 5-1 SCHEMATIC	5-2



SAFETY SUMMARY

GENERAL SAFETY NOTICES

The following general safety notices supplement the specific warnings and cautions appearing elsewhere in this manual. They are recommended precautions that must be understood and applied during operation and maintenance of the equipment covered herein. A listing of the specific warnings and cautions appearing elsewhere in the manual follows the general safety notices.

FIRST AID

An injury, no matter how slight, should never go unattended. Always obtain first aid or medical attention immediately.

OPERATING PRECAUTIONS

Always wear safety glasses.

Keep hands, clothing and tools clear of the evaporator and condenser fans.

No work should be performed on the unit until all start-stop switches are placed in the OFF position, and power supply is disconnected.

Always work in pairs. Never work on the equipment alone.

In case of severe vibration or unusual noise, stop the unit and investigate.

MAINTENANCE PRECAUTIONS

Beware of unannounced starting of the evaporator and condenser fans. Do not open the unit cover before turning power off.

Be sure power is turned off before working on motors, controllers, solenoid valves and electrical controls. Tag circuit breaker and power supply to prevent accidental energizing of circuit.

Do not bypass any electrical safety devices, e.g. bridging an overload, or using any sort of jumper wires. Problems with the system should be diagnosed, and any necessary repairs performed by qualified service personnel.

When performing any arc welding on the unit, disconnect all wire harness connectors from the modules in the control box. Do not remove wire harness from the modules unless you are grounded to the unit frame with a static-safe wrist strap.

In case of electrical fire, open circuit switch and extinguish with CO₂ (never use water).



SPECIFIC WARNINGS AND CAUTIONS

 **WARNING**

Use of an electro-magnetic valve as a means of positive shutoff for service is not recommended for safety, or good service practice.

 **WARNING**

Be sure to observe warnings listed in the safety summary in the front of this manual before performing maintenance on the hvac system

 **WARNING**

Read the entire procedure before beginning work. Park the vehicle on a level surface, with parking brake applied. Turn main electrical disconnect switch to the off position.

 **WARNING**

Do Not Use A Nitrogen Cylinder Without A Pressure Regulator

 **WARNING**

Do Not Use Oxygen In Or Near A Refrigeration System As An Explosion May Occur.

 **WARNING**

The Filter-drier May Contain Liquid Refrigerant. Slowly Loosen The Connecting Nuts And Avoid Contact With Exposed Skin Or Eyes.

 **CAUTION**

The 50-2104 Rooftop Systems have R134a service port couplings installed on the compressor and on the unit piping.

 **CAUTION**

To prevent trapping liquid refrigerant in the manifold gauge set be sure set is brought to suction pressure before disconnecting.

SECTION 1

DESCRIPTION

1.1 INTRODUCTION

This manual contains Operating Instructions, Service Instructions and Electrical Data for the Xcelsior Model 50-2104 Air Conditioning and Heating equipment furnished by Mobile Climate Control as shown in Table 1-1.

The system is identified with a Model/Serial number tag located inside the evaporator section, on the rear bulkhead wall of the assembly. Example is shown in Figure 1-1.

Model 50-2104 system consists of a Rooftop unit containing the condensing section, the evaporator

sections and engine compartment mounted compressor. To complete the system, the air conditioning and heating equipment interfaces, electrical cabling, refrigerant piping, engine coolant piping (for heating), duct work and other components furnished by Mobile Climate Control and/or the bus manufacturer.

Additional support manuals are shown in Table 1-2.

Operation of the unit is controlled automatically by a Mobile Climate Control Microprocessor based controller. The controls maintain the vehicle's interior temperature at the desired set point.

Table 1-1 50-2401 Models

Model	Voltage	Controller	With Heat	Single Loop	W/Covers
50-2104	24 VDC	MCC EcoTemp NG Microprocessor	Yes	X	X

Table 1-2 Additional Support Manuals

MANUAL NUMBER	EQUIPMENT COVERED	TYPE OF MANUAL
T-367PL	50-2104	Service Replacement Parts List

1.2 GENERAL DESCRIPTION

1.2.1 Rooftop Unit

The rooftop unit includes the condenser section and the evaporator sections (See Figure 1-1).

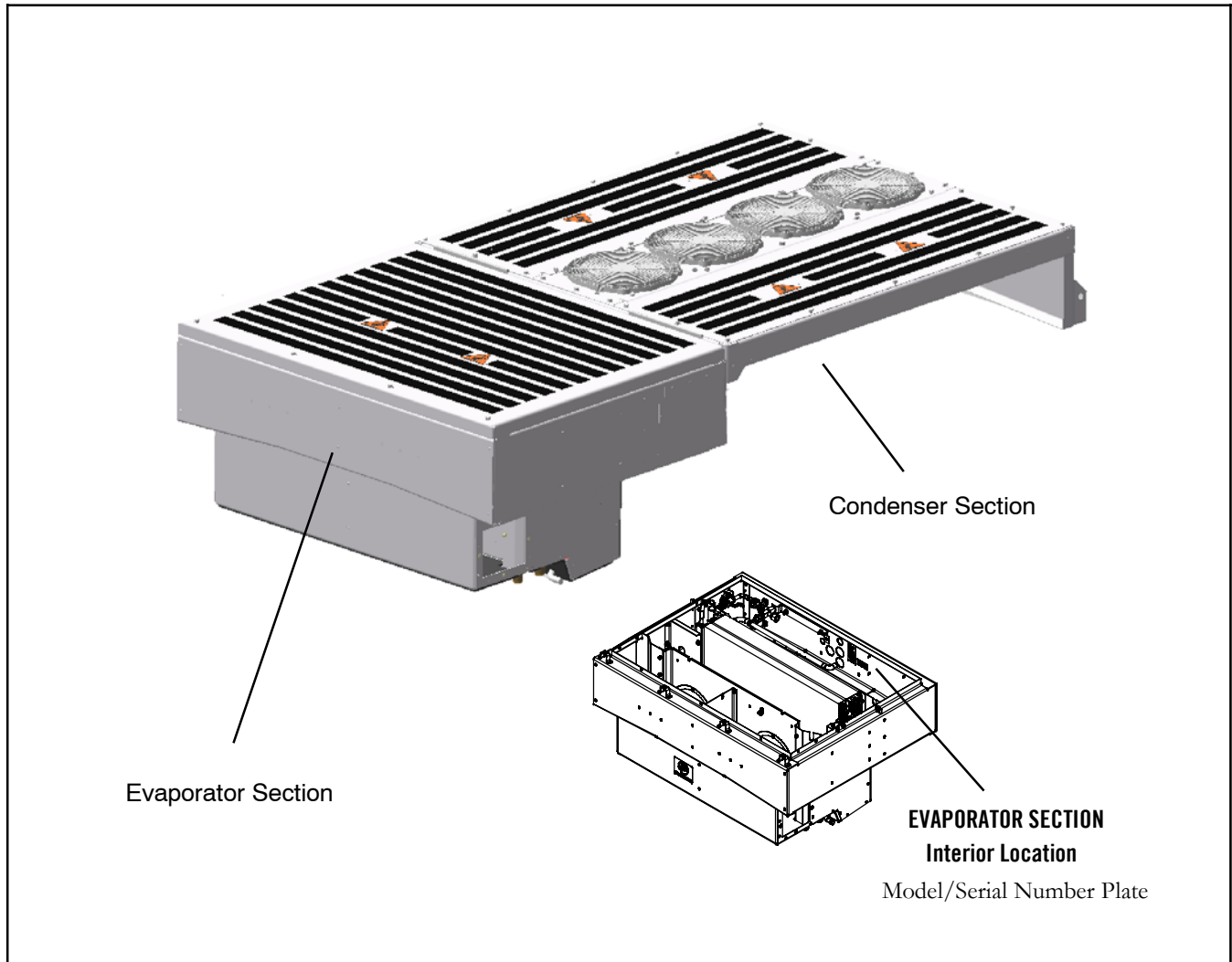

Figure 1-1 50-2104 Rooftop Unit (Xcelsior)

1.2.2 Condensing Section

The condensing section includes 2 micro-channel condenser coils, four (4) fan and motor assemblies and receiver tank assembly with sight glasses, moisture indicator and fusible plug

The condenser coils provide heat transfer surface for condensing refrigerant gas at a high temperature and pressure into a liquid at high temperature and pressure. The condenser fans circulate ambient air across the outside of the condenser tubes at a temperature lower than refrigerant circulating inside the tubes; this results in condensation of the refrigerant into a liquid. The receiver tank is also

equipped with a pressure relief valve (fusible plug) which protects the system from unsafe high pressure conditions. The filter-drier, located in the evaporator section, removes moisture and debris from the liquid refrigerant before it enters the thermostatic expansion valve in the evaporator assembly.

a. Condenser fan operation

Low Speed ON: 150 psig (10.31 bar)
 Low Speed OFF: 120 psig (8.27 bar)

High Speed ON: 225 psig (15.51 bar)
 High Speed OFF: 165 psig (11.38 bar)

1.2.3 Evaporator Sections

The evaporator section includes the evaporator coil, two (2) blower motor assemblies, thermostatic expansion valve, heater coil assembly, heater valve, filter/drier, service valves and condensate drain connections.

The evaporator coil provides heat transfer surface for transferring heat from air circulating over the outside of the coil to refrigerant circulating inside the tubes; thus providing cooling. The heating coils provide a heat transfer surface for transferring heat from engine coolant water circulating inside the tubes to air circulating over the outside surface of the tubes, thus providing heating. The fans circulate the air over the coils. The air filters (OEM supplied) remove dirt particles from the air before it passes over the coils. The thermostatic expansion valve meters the flow of refrigerant entering the evaporator coils. The heat valve controls the flow of engine coolant to the heating coils upon receipt of a signal from the controller. The condensate drain connections provide a means for connecting tubing for disposing of condensate collected on the evaporator coils during cooling operation.

1.2.4 MCC Microprocessor

The MCC controller maintains desired temperature set point by controlling compressor capacity, fan speeds and heat valve operation. Refer to Section 2, for operational sequences.

1.3 REFRIGERATION SYSTEM COMPONENT SPECIFICATIONS

a. System Capacity: Cooling - 120,000 Btu/Hr (35 kW)
 Heating - 126,000 Btu/Hr (37 kW)

b. Refrigerant Charge R-134a (Approximate)

NOTE

Refrigerant charge will depend on hose lengths and diameters; or if there is an In-Dash unit (front evaporator). The following should only be used as a guideline.

50-2104 with 05G Compressor
13 ± 0.5 Pounds (5.9 ± 0.23 kg)

c. Compressor

Compressor	05G
No. Of Cylinders	6
Weight, (Dry) With Clutch	145 Lbs. (66 kg)
Oil Charge	5.5 pints (2.6 liters)

d. Thermostatic Expansion Valve:

7 Ton Capacity- Adjustable

e. High Pressure Switch (HPS) *Normally Closed*

Opens at: 360 ± 10 psig (24.82 ± 0.68bar)

Closes at: 285 ± 15 psig (19.65 ± 0.68bar)

f. Low Pressure Switch (LPS) *Normally Open*

Opens at: 6 ± 3psig (0.41 ± 0.20 bar)

Closes at: 25 ± 3 psig (1.7 ± 0.20 bar)

g. Water Temperature Switch (WTS) (If Equipped)

[Bus Manufacturer Supplied - Suggested close on temperature rise at 105°F (41°C)]

1.4 ELECTRICAL SPECIFICATIONS - MOTORS

a. Evaporator Blower/Motor

Evaporator Motor	Brushless
	24 VDC
Full Load Amps (FLA)	~25
Bearing Lubrication	Factory Lubricated (additional grease not required)

b. Condenser Fan Motor

Condenser Motor	Brushless
	24 VDC
Full Load Amps (FLA)	~7
Bearing Lubrication	Factory Lubricated (additional grease not required)

c. Temperature Sensors (All)

Input Range: -40 to 167° F (-40 to 75°C)

Output: NTC 10K ohms at 77° F (25°C)

d. Ambient Sensor (Controls Compressor Outputs)

Opens at: 43° F (6.1°C)

Closes at: 47° F (8.3°C)

1.5 SAFETY DEVICES

System components are protected from damage caused by unsafe operating conditions with safety devices. Safety devices with Mobile Climate Control supplied equipment include high pressure switch (HPS), low pressure switch (LPS), fusible plug, circuit breakers and fuses.

a. Pressure Switches

High Pressure Switch (HPS)

During the air conditioning cycle, compressor clutch operation will automatically stop if the HPS switch contacts open due to an unsafe operating condition. Opening HPS contacts de-energizes the compressor clutch shutting down the compressor. The high pressure switch (HPS) is installed at the compressor assembly. See paragraph 1.3 for specifications.

Low Pressure Switch (LPS)

The low pressure switch is installed on the compressor assembly and opens on a pressure drop to shut down the system when a low pressure condition occurs. See paragraph 1.3 for specifications.

b. Fuses and Circuit Breakers

The Relay Board is protected against high current by an OEM supplied circuit breaker or fuse located in the bus battery compartment (100 Amp for 24 VDC systems is recommended). Independent fuses and circuit breakers protect electrical circuits from high current conditions. During a high current condition, the circuit protection may open.

c. Ambient Lockout

Auto Mode

Opens Compressor Output at: 43° F (6.1°C)
Closes Compressor Output at: 47° F (8.3°C)

Defrost Mode

Opens Compressor Output at: 28° F (-2.2°C)
Closes Compressor Output at: 32° F (0°C)

The ambient temperature sensor measures the condenser inlet air temperature. These settings protect the compressor from damage caused by operation at low pressures.

d. Unloader Operation

The compressor is equipped with two unloaders to allow compressor operation at 33%, 66% or 100% capacity.

Low Pressure Control

Energizes Unloader Output 1 (Unloads) at: 25 psig (1.7 bars)
De-energizes Unloader Output1 (Loads) at: 32 psig (2.2 bars)

Energizes Unloader Output 2 (Unloads) at: 21 psig (1.4 bars)
De-energizes Unloader Output1 (Loads) at: 28 psig (1.9 bars)

High Pressure Control (below 87 F (30.8C))

Energizes Unloader Output (Unloads) at: 300 psig (20.7 bars)

High Pressure Control (above 92 F (33.6C))

Energizes Unloader Output (Unloads) at: 320 psig (23.4 bars)

In response to the high pressure conditions above, the unloader remains energized for 2 minutes. Once the pressures return below the parameters listed, the unloader circuit will de-energize.

1.6 AIR CONDITIONING REFRIGERATION CYCLE

When air conditioning (cooling) is selected by the controller, the unit operates as a vapor compression system using R-134a as a refrigerant (See Figure 1-2 refrigerant flow diagram). The main components of the system are the A/C compressor, air-cooled condenser coils, filter-drier, thermostatic expansion valve, liquid line solenoid valve and evaporator coils.

The compressor raises the pressure and the temperature of the refrigerant and forces it into the condenser tubes. The condenser fan circulates surrounding air (which is at a temperature lower than the refrigerant) over the outside of the condenser tubes. Heat transfer is established from the refrigerant (inside the tubes) to the condenser air (flowing over the tubes). The condenser tubes have fins designed to improve the transfer of heat from the refrigerant gas to the air; this removal of heat causes the refrigerant to liquefy, thus liquid refrigerant leaves the condenser and flows to the filter-drier.

The refrigerant passes through a filter-drier where a desiccant keeps the refrigerant clean and dry.

From the filter-drier, the liquid refrigerant then flows through the liquid line to the sight-glass and then to the thermostatic expansion valve. The thermal expansion valve reduces pressure and temperature of the liquid and meters the flow of liquid refrigerant to the evaporator to obtain maximum use of the evaporator heat transfer surface.

The low pressure, low temperature liquid that flows into the evaporator tubes is colder than the air that is circulated over the evaporator tubes by the

evaporator fans. Heat transfer is established from the evaporator air (flowing over the tubes) to the refrigerant (flowing inside the tubes). The evaporator tubes have aluminum fins to increase heat transfer from the air to the refrigerant; therefore the cooler air is circulated to the interior of the bus.

The transfer of heat from the air to the low temperature liquid refrigerant in the evaporator causes the liquid to vaporize. This low temperature, low pressure vapor passes through the suction line and returns to the compressor where the cycle repeats.

1.7 HEATING CYCLE

Heating circuit (See Figure 1-3) components furnished by Mobile Climate Control include the heater cores and solenoid operated heat valve. Components furnished by the bus manufacturer may include a water temperature switch (WTS), boost water pump and floor blower convectors.

The controller automatically controls the heat valves during the heating mode to maintain required temperatures inside the bus. Engine coolant (glycol solution) is circulated through the heating circuit by the engine and an auxiliary boost water pump. When the heat valve solenoids are energized, the valves will open to allow engine coolant to flow through the heater coils. The valves are normally closed.

NOTE: In order to ensure water is entering the heater coils sufficiently heated, it is suggested that the OEM supplied Water Temperature Switch (WTS), (If equipped) close on temperature rise at 105°F (40.5°C).

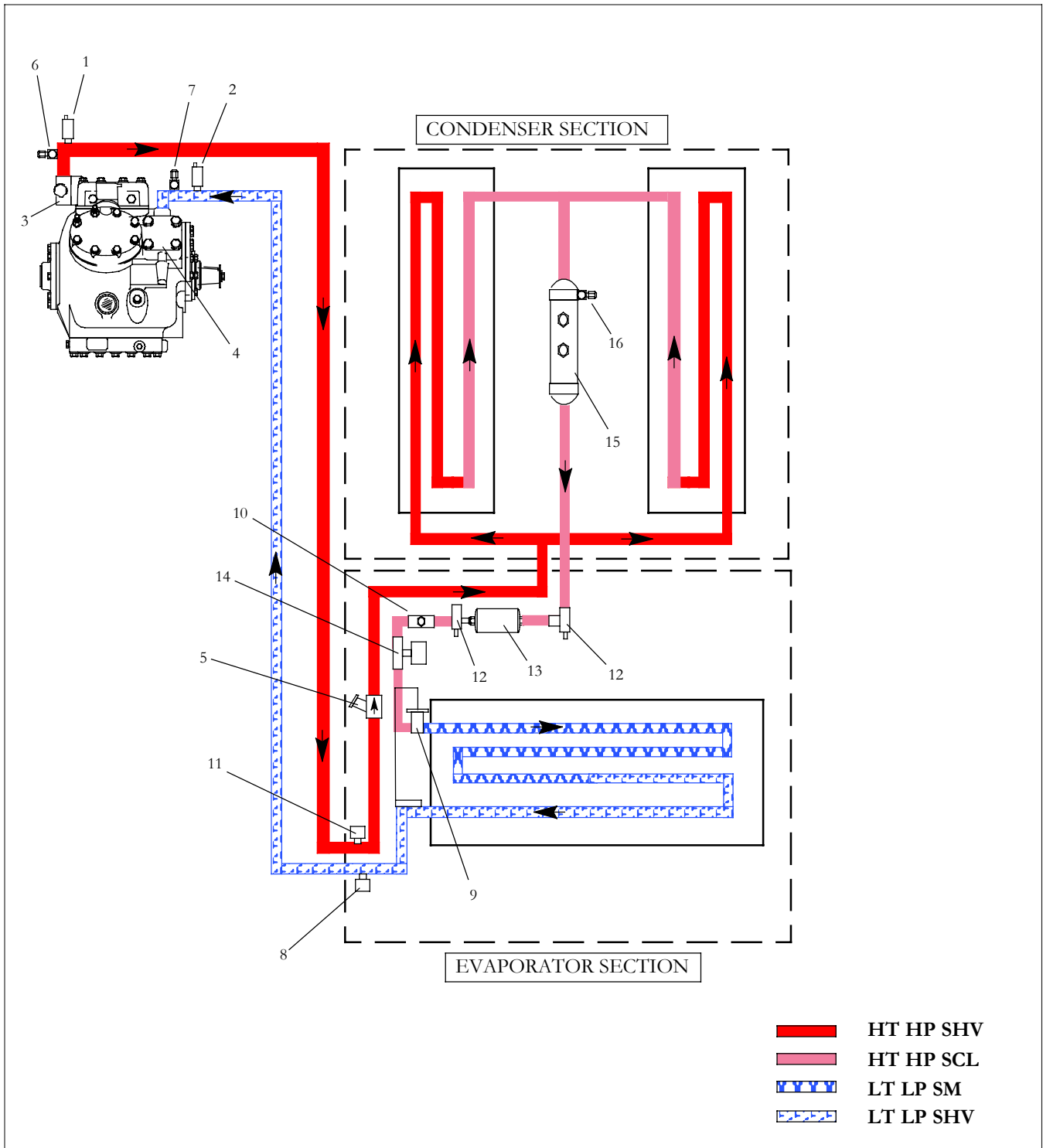

- 1. High Pressure Switch
- 2. Low Pressure Switch
- 3. Discharge Service Valve
- 4. Suction Service Valve
- 5. Discharge Check Valve
- 6. Service Port, (High Side)
- 7. Service Port, (Low Side)
- 8. Pressure Transducer (SPT)

- 9. Thermal Expansion Valve (TXV)
- 10. Liquid Line Sight Glass
- 11. Pressure Transducer (DPT)
- 12. Filter Drier Service Valve
- 13. Filter Drier
- 14. Liquid Line Solenoid Valve
- 15. Receiver Tank
- 16. Fusible Plug

Figure 1-2 Refrigerant Flow Diagram

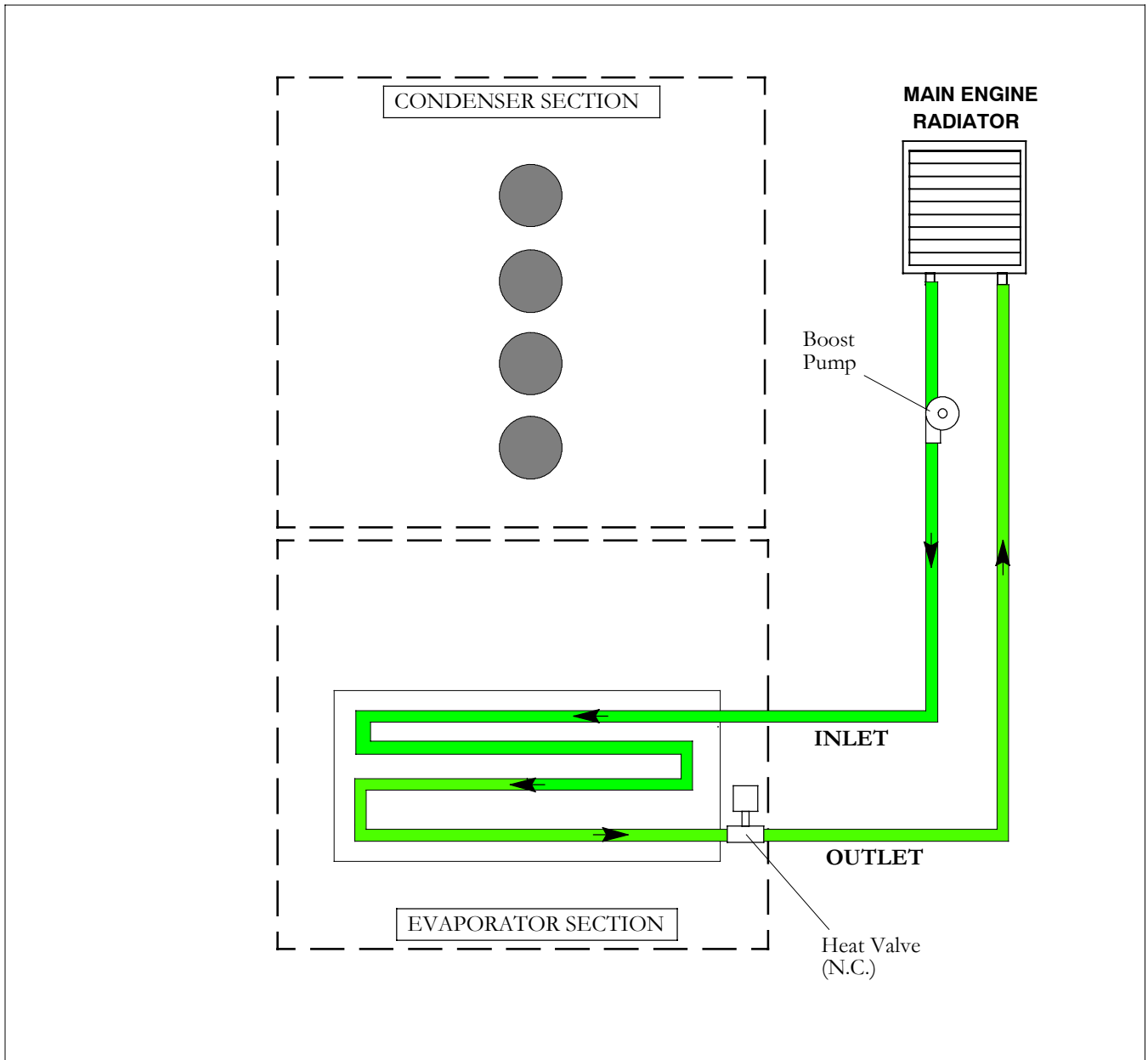

Figure 1-3 Heat Flow Diagram

SECTION 2

OPERATION of MCC XCELSIOR DRIVER DISPLAY

2.1 General Description

Operation of the MCC unit Y50-2104 is controlled through the MCC Driver's display.

When the MCC Display is used to control operation, the Mode selection is selected using the "Mode" button (item 3) on display, shown in Figure 2-1.

Ability to view system pressures, sensor temperatures, component status, etc. is available Through the MCC Display Module.

2.2 STARTING, STOPPING AND OPERATING INSTRUCTIONS

The MCC Drivers Display Module is marked with international symbols (See Figure 2-1).

Before starting, electrical power must be available from the bus power supply.

A circuit breaker/fuse in the battery compartment passes power for the clutch, evaporator and condenser assemblies.

2.2.1 Starting

- a. If the engine is not running, start the engine.
- b. When the 24VDC power is applied, the driver display will be ready to except request for system operation. Press the On/Off key (Item 1, Figure 2-1) on the display to trigger the start up sequence, controlled by the MCC Drivers display module.

2.2.2 Stopping

Toggleing the On/Off key (Item 1, Figure 2-1) on the display again will stop the system operation controlled by the MCC Drivers display module.

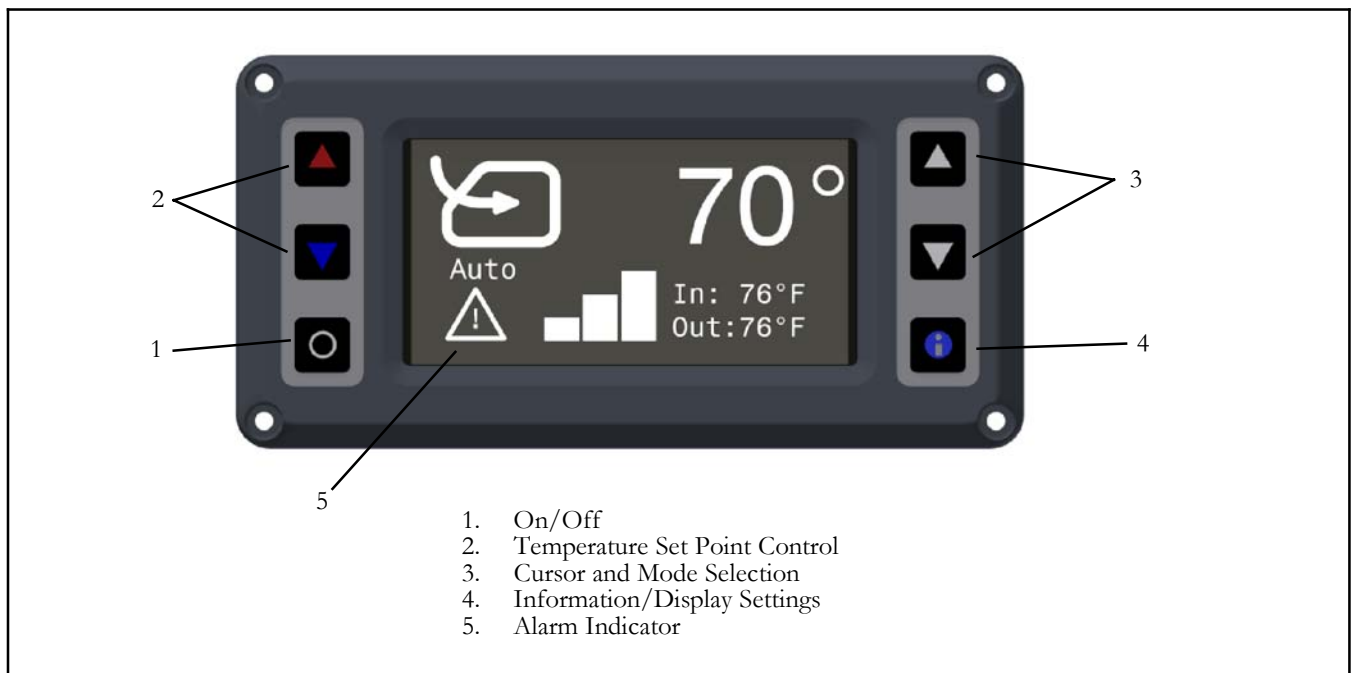

Figure 2-1 Driver Display Module- Control Layout

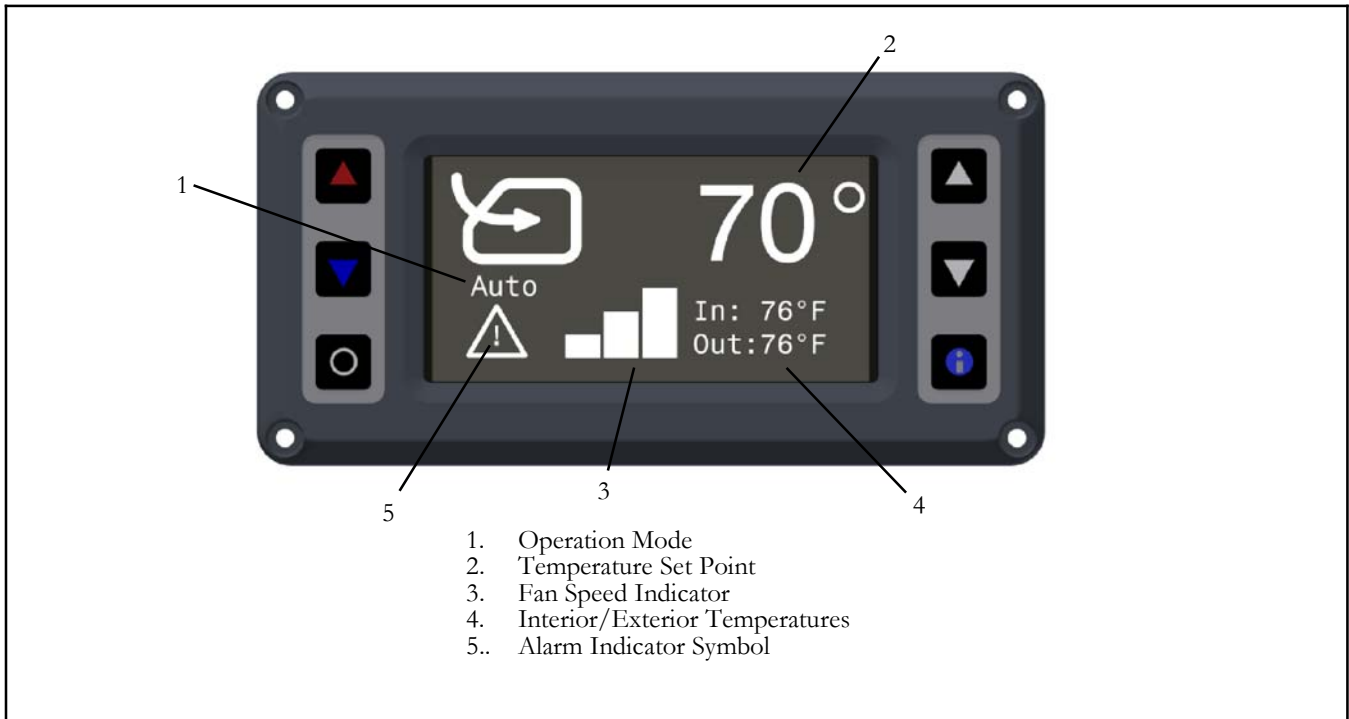

Figure 2-2 Driver Display Module- Display Layout

2.3 SEQUENCE OF OPERATION

2.3.1 Function of Keys when “Engine On” and controller active:

- a. **On/Off Key** - Turns HVAC unit On or Off, unless OEM supplied switches are installed. It also is used to exit diagnostic menu.
- b. **Temperature Set Point Control Keys** - These buttons increase or decrease the temperature set point for the passenger area HVAC unit.
- c. **Cursor/Mode Selection Key**- Used to toggle through parameter settings in diagnostic mode or set the operating mode to Auto, Heat, Vent, Cool, and Defrost in normal display mode.

- d. **Information/Display Settings Key** - Allows access to display settings and system diagnostics.

2.3.2 Illuminating Indications (Display)

With “Engine-On” and Controller active by the On/Off button.

NOTE:

Depending on Customer specification, the modes of operation may be controlled strictly through manual switches provided in the driver's area.



2.4 BASIC OPERATING INSTRUCTIONS

When the engine is running, press the On/Off button on display.

2.4.1 Display

When the unit is ON, the display shows the interior set point temperature, current blower speed setting, mode selection and Interior/Exterior temperatures.

2.4.2 Interior Set Point Temperature Control

Press the UP (Red) or Down (Blue) keys to set the desired interior temperature.

The temperature can be adjusted between 62° F (16° C) and 82° F (28° C).

2.4.3 Blower Speed Setting

Blower speed operation will be set for high or low speed operation automatically through software, or can be set through manual switches provided at the driver area.

2.4.4 Mode Selection Descriptions

- a. **Auto** - In the auto mode, the ECC node will adjust the individual components to maintain the desired set point temperature.

In the auto mode, the evaporator fans will operate in an “Ultra” high speed to achieve desired set point faster, when the interior temperature is greater than 5.4°F (3°C), from desired set point.

In the auto mode, the A/C system will continue to operate when set point is reached, and will energize the boost pump and de-energize the heat solenoid valve to maintain temperature. This is referred to as Reheat mode, to provide additional de-humidification of interior space.

The reheat mode will be disabled if the outside ambient air temperature is below 43° F (6.1° C).

- b. **Cooling** - In the cooling mode, the Compressor, condenser fans and evaporator fans will be energized. The heater solenoid valve will be energized (closed), to provide full cooling.

The compressor and condenser fans will be de-energized 2 degrees F below set point. The evaporator fans will continue to operate to circulate interior air.

- c. **Heating** - In the heating mode, the compressor and condenser fans will remain de-energized. Evaporator fans will be energized. The boost pump will be energized, and the heat solenoid valve will be de-energized (opened), to allow engine coolant to flow through the heater coils. If the interior temperature is more than 5° F (3° C) below set point, the floor blowers (if equipped) will also be energized.

- d. **Defrost** - In the defrost mode, the boost pump will be energized to provide engine coolant flow to the drivers unit to allow defogging of the windshield.

Defrost Override - In the event the main HVAC system is “OFF”, the ability of the OEM to provide a signal to the controller to energize the Boost Pump to provide engine coolant flow for the Drivers Defroster is provided.

- e. **Vent** - In the vent mode, the evaporator blowers are operated to circulate air in the bus.

2.4.5 Capacity Control “Ladder” Diagrams

Ladder diagrams showing system operational control logic for Auto/ Cool (Reheat system), and Heat, can be seen in Figure 2-3.

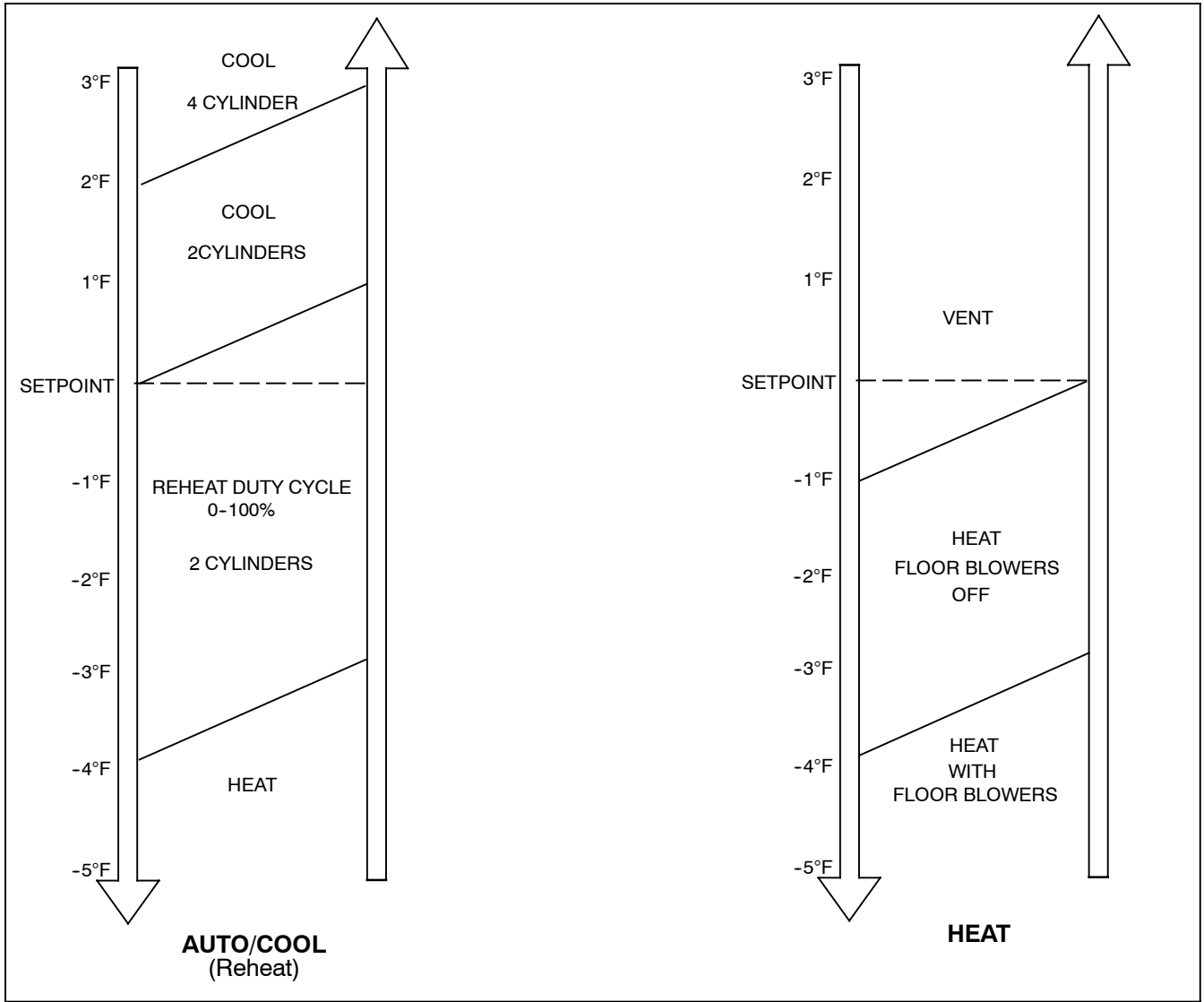

Figure 2-3 Capacity Control Ladder Diagrams

2.4.6 Display Settings

To adjust display settings, from the main menu:

- Press the “Information” button to enter the “View” screen (Item 4 in Figure 2-1).
- Press and release both “Temperature Control UP” and “Cursor UP” buttons (Items 3 in Figure 2-4) to access the display set-up screen.
- To adjust settings, press the up or down cursor keys to scroll to desired parameter (Item 3 in Figure 2-1).
- To adjust settings, press the up or down temperature control keys to scroll to adjust parameter
- After adjustment, press “Information” button (Item 4 in Figure 2-1) to exit set-up screen.

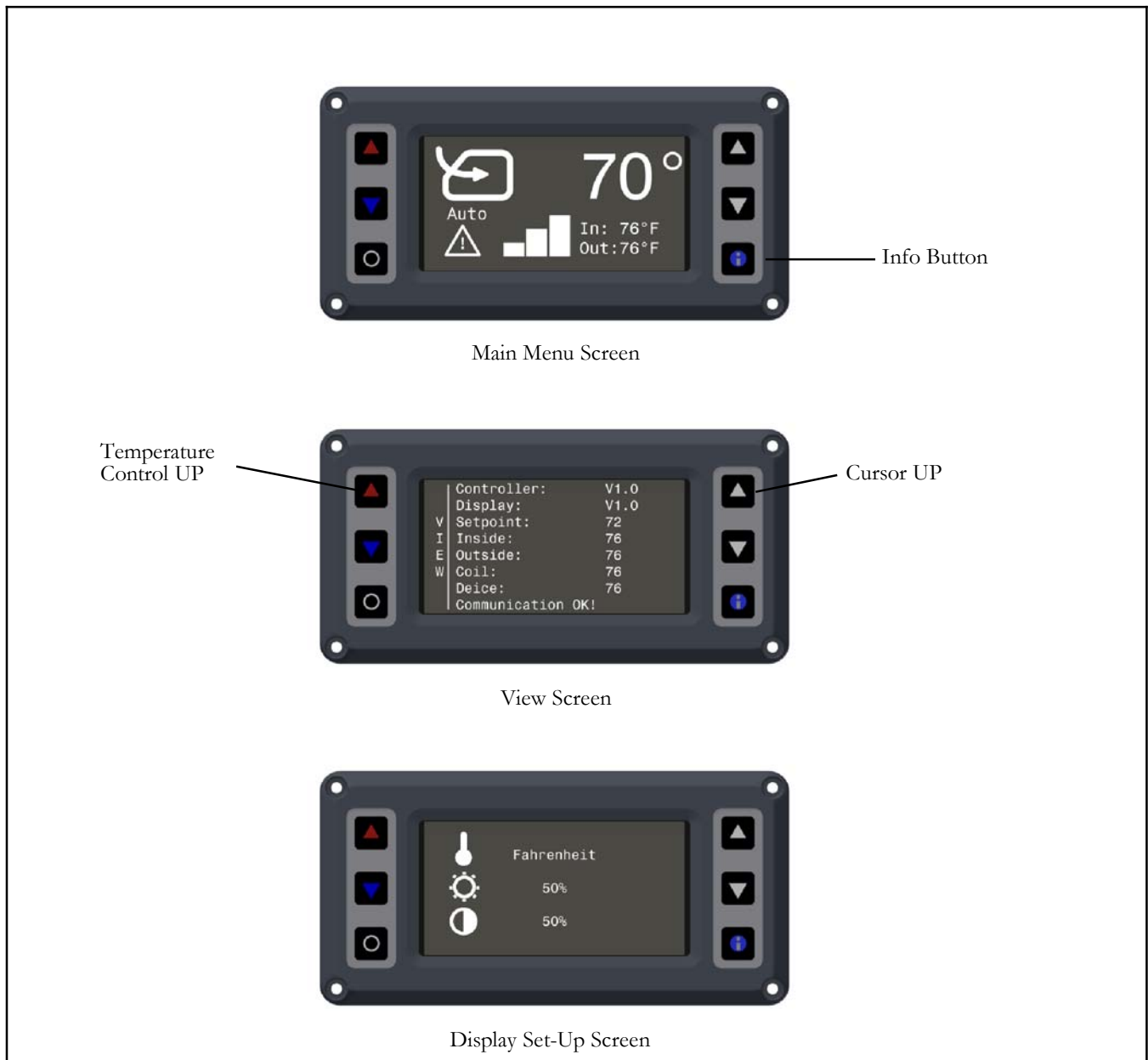

Figure 2-4 HVAC DISPLAY SETTINGS

2.4.7 HVAC Information Screens

The information screens will allow user to view the system parameters of temperature sensors, operation hours of components and HVAC equipment error logs. To enter the information menu:

- a. Press the “Information” button (Item 4 in Figure 2-1).
- b. To scroll through the “Information” screens, use the “Up and Down Cursor” buttons (Items 3 in Figure 2-1).

Examples of the available screens can be seen in Figure 2-5.

- c. To reset individual error and timer hours, use temperature buttons (Item 2 in Figure 2-1). to select parameter and press On/Off button (Item 1 in Figure 2-1) to reset the parameter.
- d. To reset all error and timer hours shown on a screen, press up or down temperature button (Item 2 in Figure 2-1) until all “=0” flashes on screen. To reset all parameters shown, press On/Off button (Item 1 in Figure 2-1) .
- e. To exit the Information screens, press the “Information” button (Item 4 in Figure 2-1).

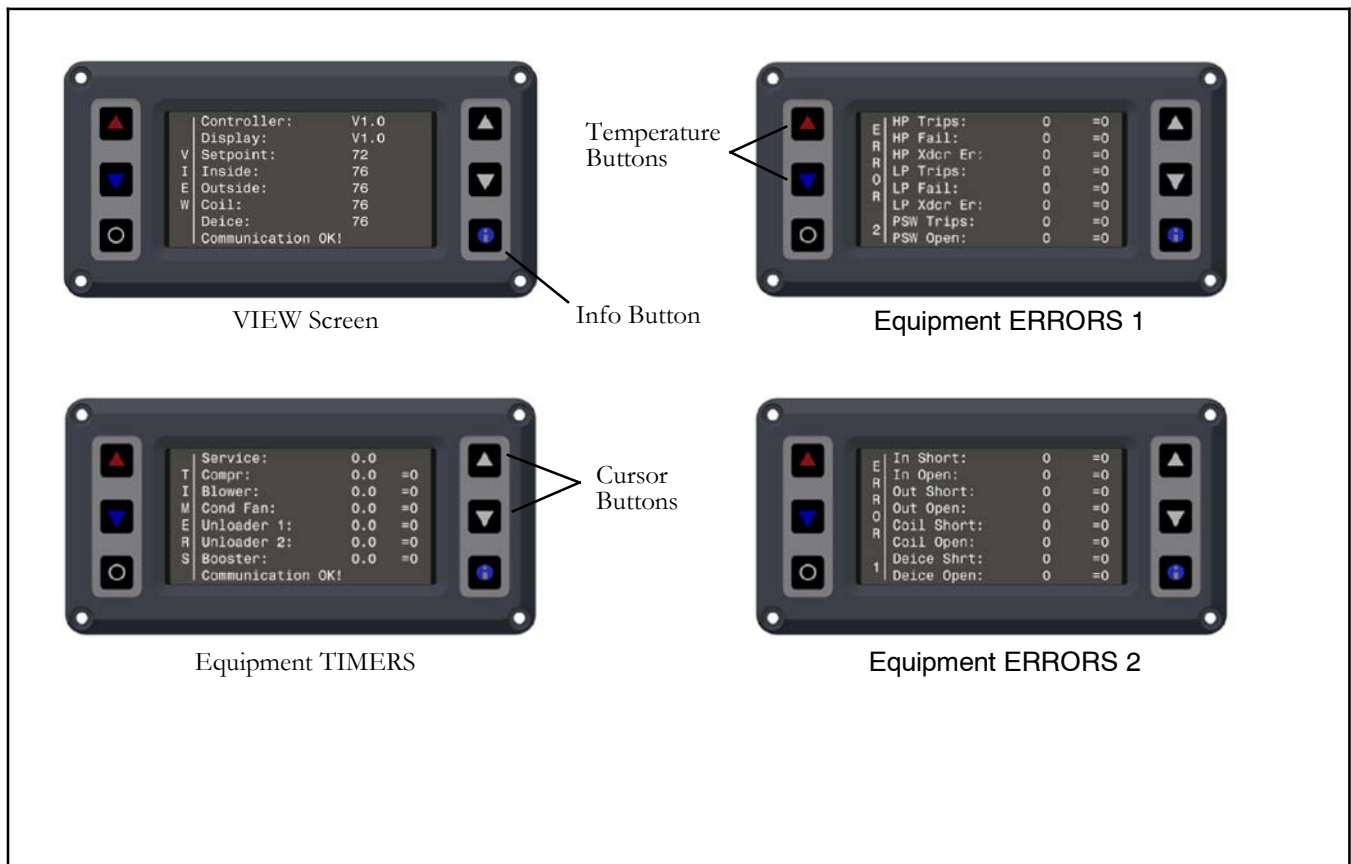

Figure 2-5 HVAC INFORMATION SCREENS

2.4.8 HVAC Diagnostics Screens

The Diagnostics screens will allow user to view the real time status of system components. These screens will aide in troubleshooting system problems when necessary. Outputs monitored include, pressure transducers, pressure switches, compressor unloaders, condenser fan and LLS status, heat valve, boost pump, floor blower and engine coolant switch status . To enter the diagnostic screens:

- a. Press the “Information” button (Item 4 in Figure 2-1).
- b Scroll through the screens by pressing the “Cursor” buttons (Item 3 in Figure 2-1), until diagnostic screens are shown.
- c To exit the diagnostics screens, press the “Information” button (Item 4 in Figure 2-1).

Examples of the available screens can be seen in Figure 2-6.



Figure 2-6 HVAC DIAGNOSTIC SCREENS

2.4.9 HVAC Alarm Description

The MCC Eco Temp NG Controller will notify user in the event there is a problem or interruption in system control. The broadcasted alarms are reported to the Eco Temp NG driver display and A/C Fail Light (if applicable).

a. High or Low pressure Condition

In the event a high pressure or low pressure condition occurs, the compressor and liquid line solenoid will be disabled for a minimum of one minute. High or Low pressure can be triggered by either a pressure transducer or physical pressure switch.

1) For high pressure condition, the condenser and evaporator fan circuits remain energized to bring the system pressure down. After the one minute compressor “Off” cycle, if pressures return to operational limits, the compressor circuit will re-energize.

If the high pressure condition occurs more than four (4) times within a 20 minute period, the compressor, LLS and condenser circuits will be locked out and an alarm will be broadcast to the Driver display and A/C Fail light.

2) For low pressure condition, the condenser and evaporator fan circuits remain energized. After the one minute compressor “Off” cycle, if pressures return to operational limits, the compressor circuit will re-energize.

If the low pressure condition occurs more than four (4) times within a 20 minute period, the compressor, LLS and condenser circuit will be locked out and an alarm will be broadcast to the Driver display and A/C Fail light.

b. High or Low Transducer Failure

In the event a high pressure or low pressure transducer fails, the compressor, liquid line solenoid and condenser fans will remain energized, and the compressor will unload to two (2) cylinder operation to allow the system to provide 33% capacity until condition can be corrected. High and low pressure switches will disable the cooling circuit in the event system pressures reach an unsafe condition.

c. Sensor Failures

In the event an out of range (Open/Short) condition occurs with the Return Air, Outside Air, Deice, or Coil sensors, the system will be unable to recognize these parameters for proper operation of A/C system. If one of these conditions occurs, the Controller will trigger a code on the display to alert Driver of this condition.

When alarms occur, the ERROR screen will assist in identifying the cause of the alarm. Follow instructions in Section 2.4.7 for instructions for accessing the ERROR screens.

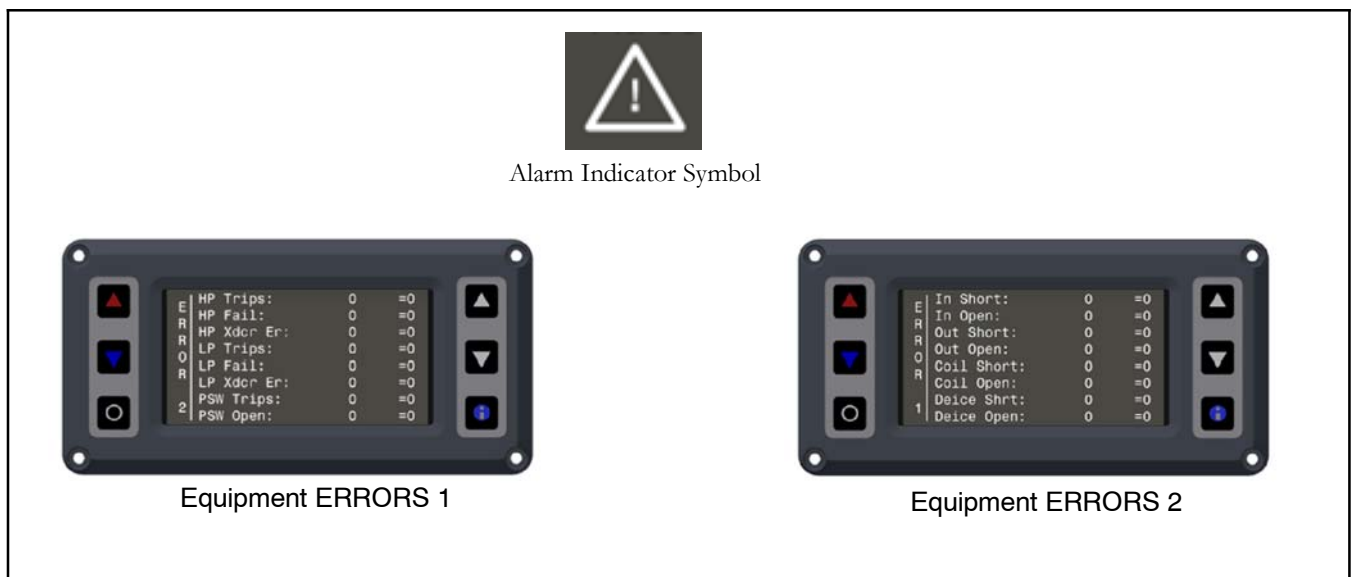

Figure 2-7 MCC Eco NG Display Alarms

2.5 MCC Eco NG Coolview

MCC Coolview is designed to assist in monitoring, diagnosing and troubleshooting of the vehicle HVAC system via a communication cable between the controller and laptop/remote computer.

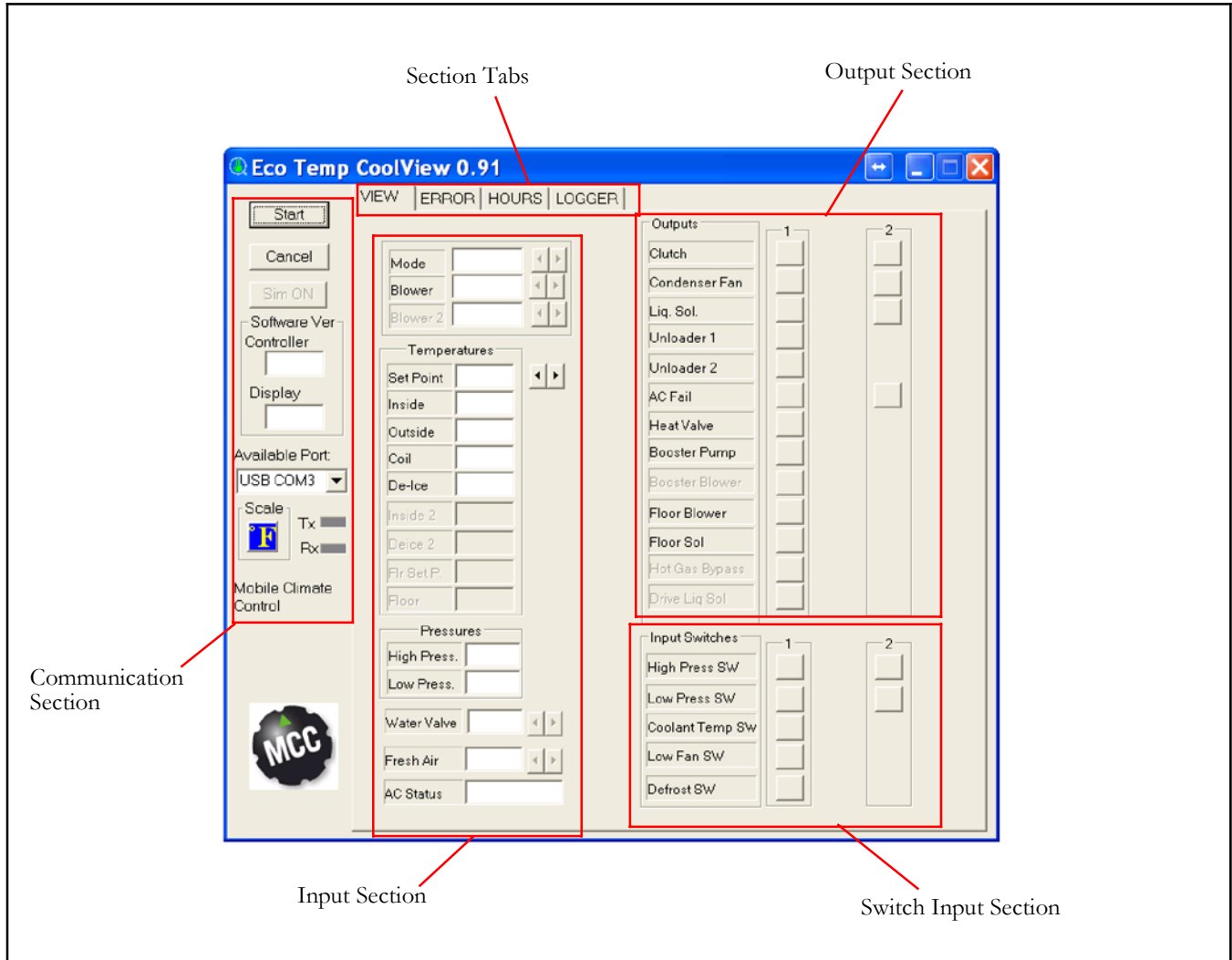

Figure 2-8 MCC Eco NG Coolview (Example Screen shot)

2.5.1 Starting the MCC Coolview Application

- a. Connect USB end of USB to RS-485 converter (MCC P/N 35-0735) to USB port of computer.
- b. Connect RS-485 end of USB to RS-485 converter to controller's RS-485 communication cable.
- c. Connect RS-485 end of USB to RS-485 converter to controller's RS-485 communication cable.
- d. Open Eco NG Coolview software on computer.
- e. Choose communication port associated with communication cable by selecting the drop down list under "Available Port" section in Coolview screen (See Figure 2-9).
- f. Click "Start" button (See Figure 2-9) to begin communication between controller and Eco NG Coolview. In normal operation, the "Rx" communication light on Eco NG coolview screen and USB to RS-485 converter will flash to indicate Communication has been established. If transmitting a command, such as "sim on" or re-setting errors, the "Tx" will flash to indicate such.
- g. Once communication has been established, software version of controller and display will be shown on Eco NG Coolview screen (See Figure 2-9).

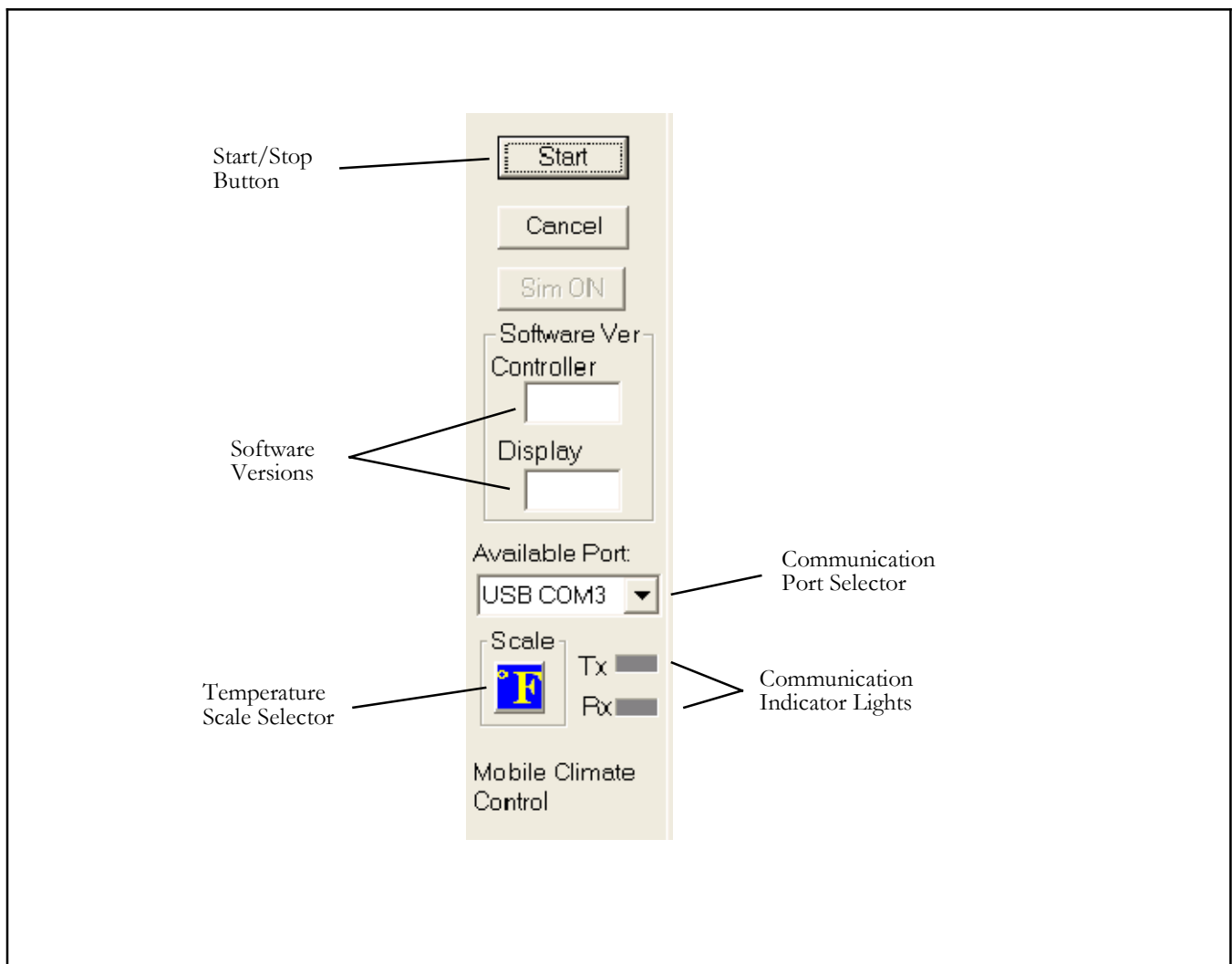

Figure 2-9 MCC Eco NG Coolview (VIEW Tab)

2.5.2 Coolview Screen Layout

a. **Inputs and Mode Indicator-** Coolview displays “real time” status of the items shown in Figure 2-10.

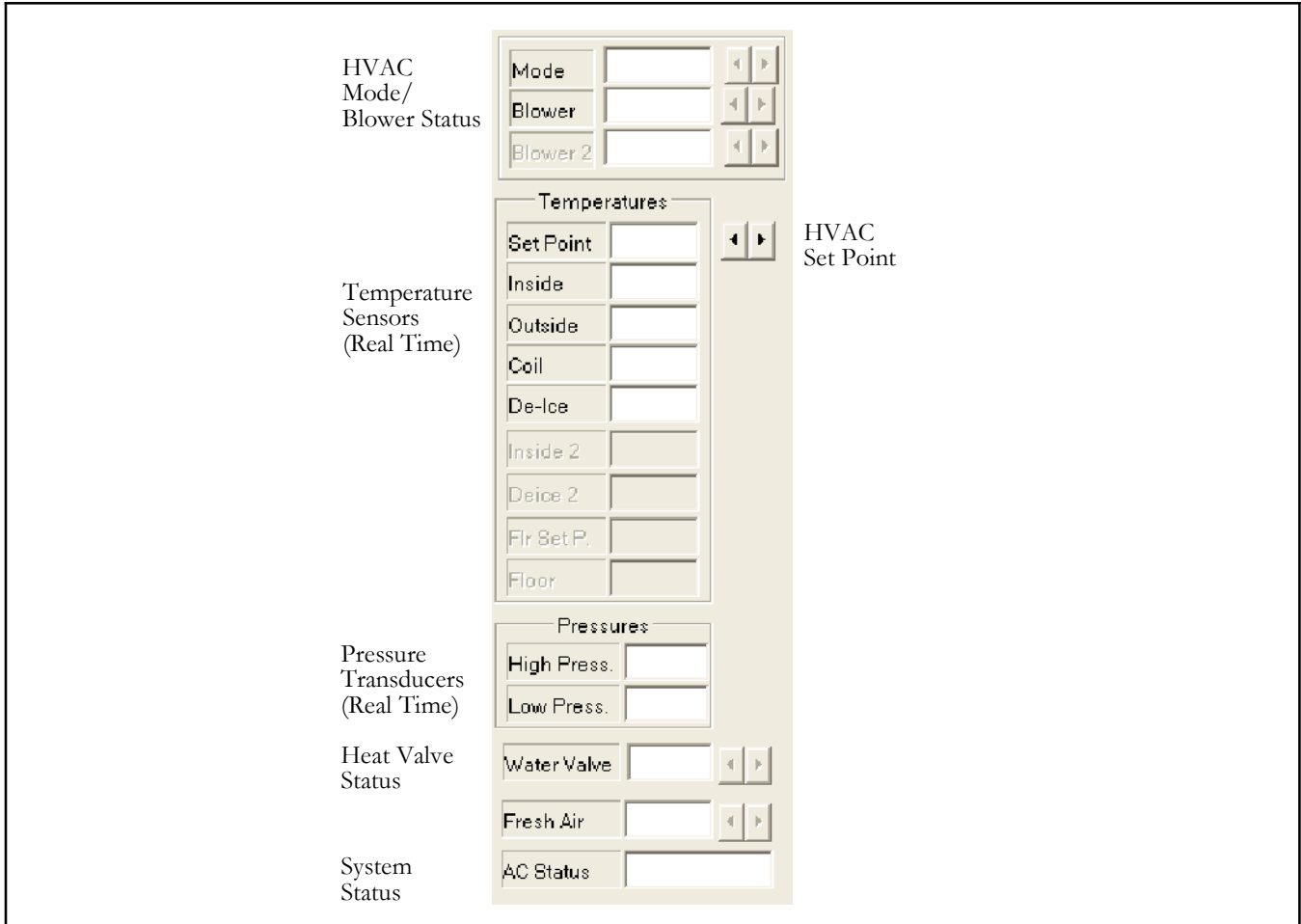

Figure 2-10 MCC Eco NG Coolview Inputs and Mode (VIEW Tab)

b. **Outputs**- Coolview displays “real time” status of the items shown in Figure 2-11. Indicator boxes will turn green when outputs are switched on, and red when switched off.

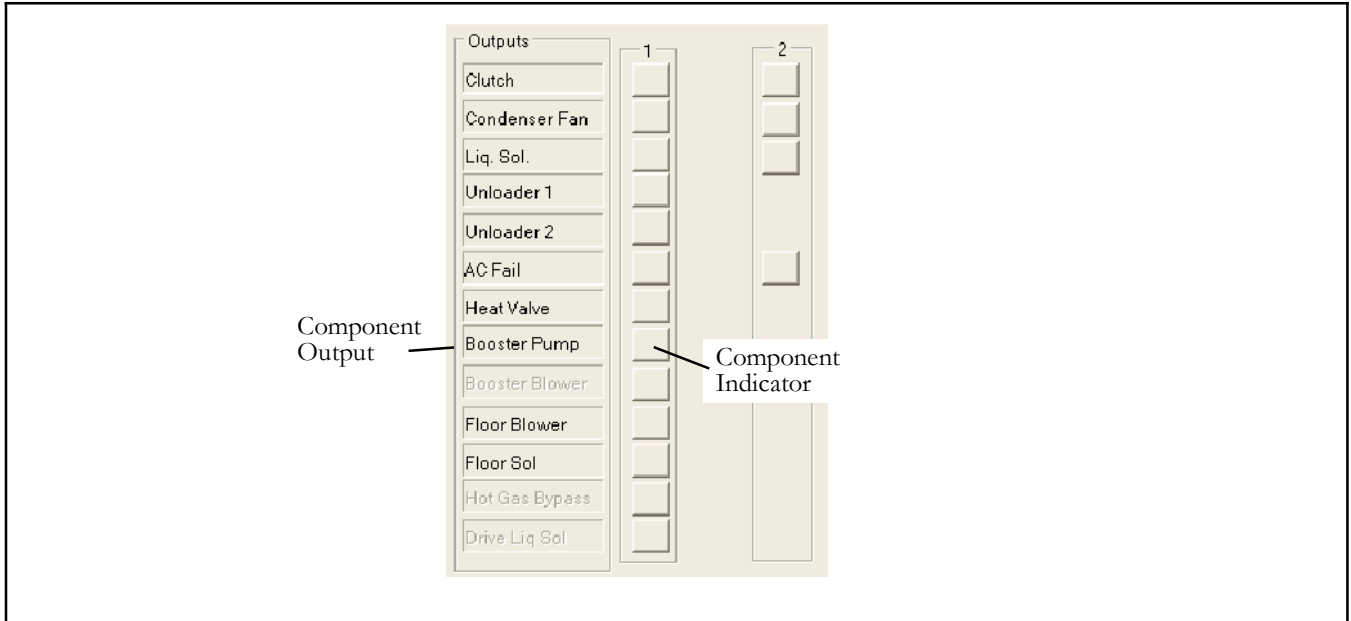

Figure 2-11 MCC Eco NG Coolview Outputs (VIEW Tab)

c. **Error List**- Coolview displays input/output, communication and compressor errors that are stored in controller's memory. Only errors that have occurred are displayed. See Figure 2-12.

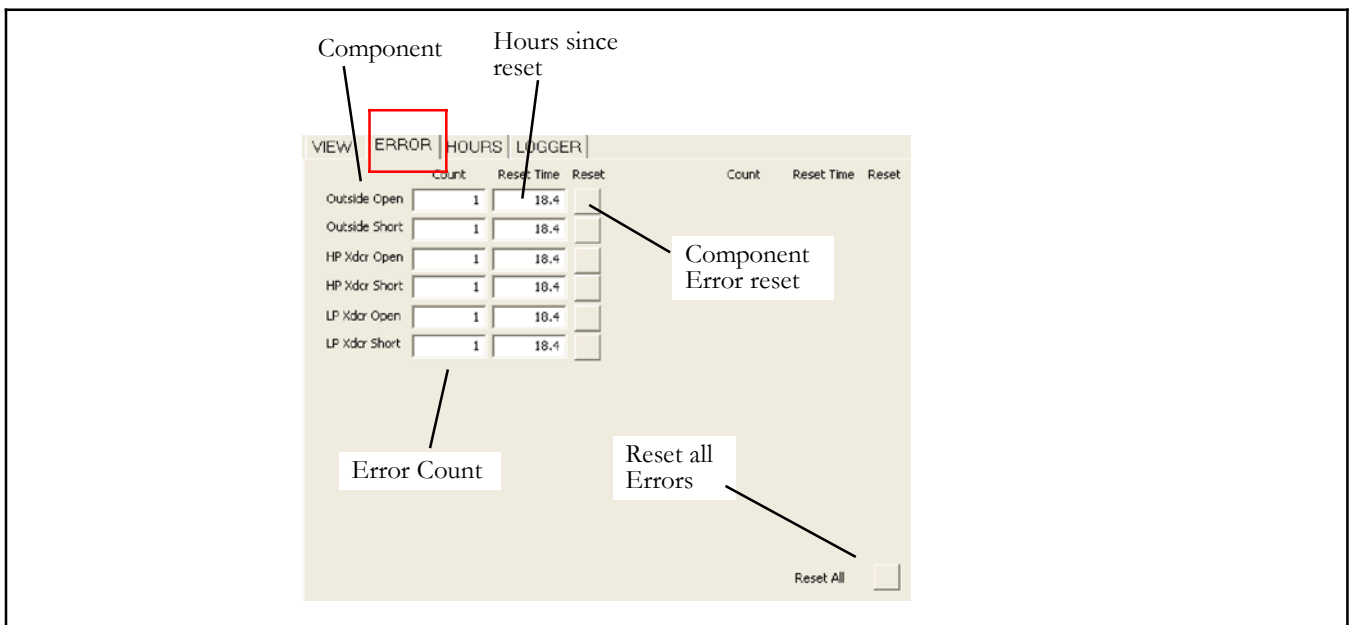

Figure 2-12 MCC Eco NG Coolview Error List (ERROR Tab)

d. **Statistics-** Coolview displays the run hours of the following items shown in Figure 2-13.

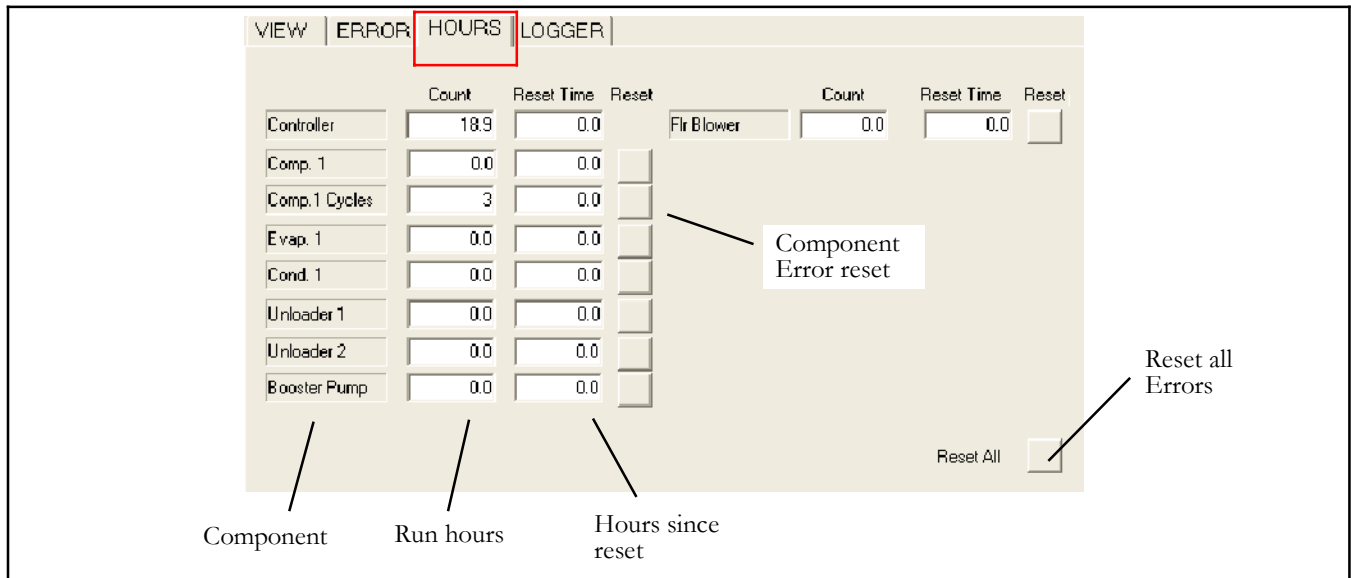

Figure 2-13 MCC Eco NG Coolview Statistics (HOURS Tab)

- e. **Simulation Mode**- In simulation mode, inputs and outputs can be toggled on/off to assist with troubleshooting and performing maintenance checks. To start simulation mode:
- 1) Click the “Simulation Button” on the Eco Ng Coolview screen to toggle the simulation mode on or off.
 - 2) Once simulation mode has been toggled On, click the “stand-by” button to the right of component.
 - 3) Click the button to the right of component to engage or adjust.

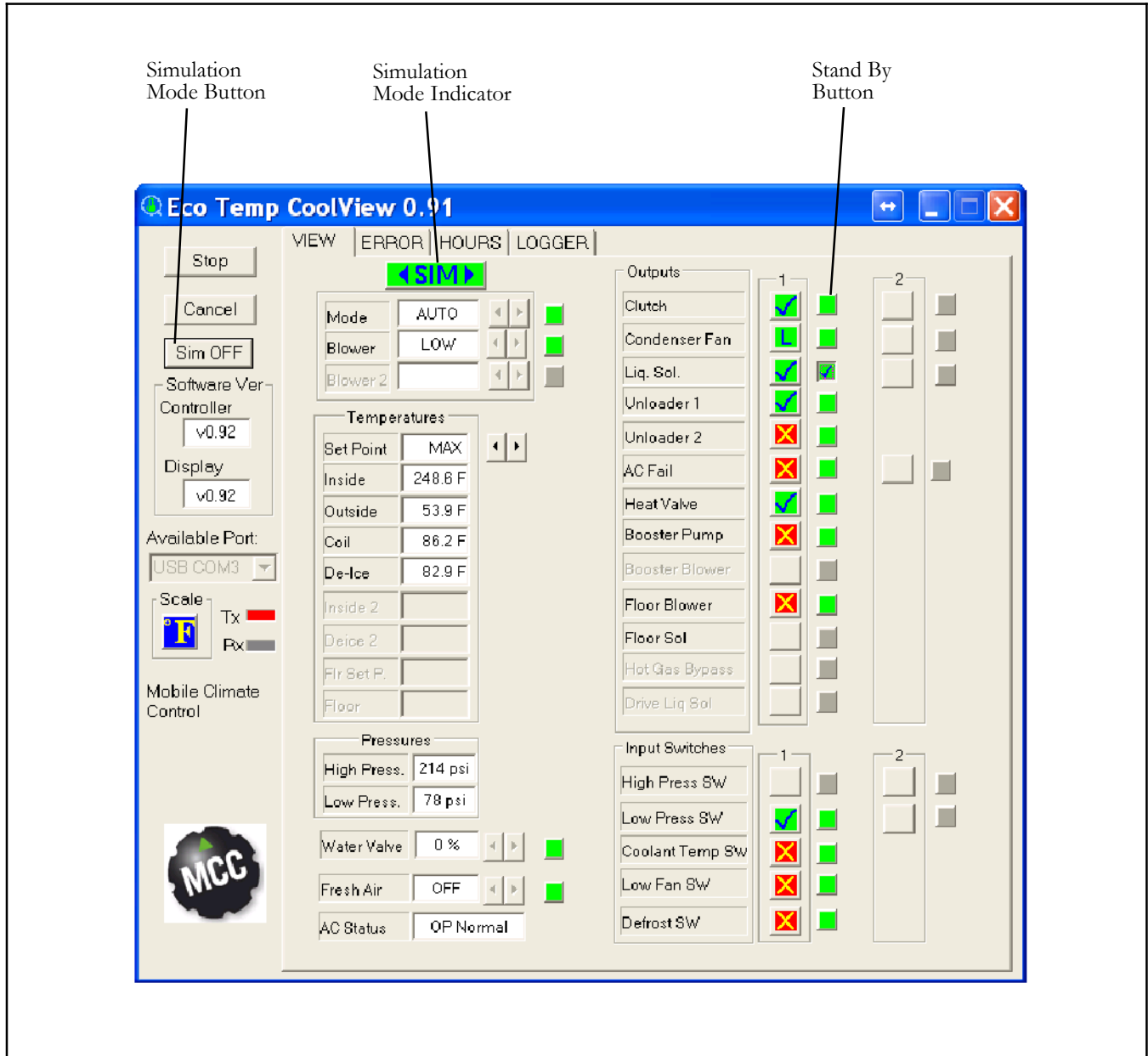

Figure 2-14 MCC Eco NG Coolview Simulation Mode

f. **Logger Tab**- The Logger retrieves data that is saved in the Data Logger on board memory. The data can be used for diagnostics and troubleshooting.

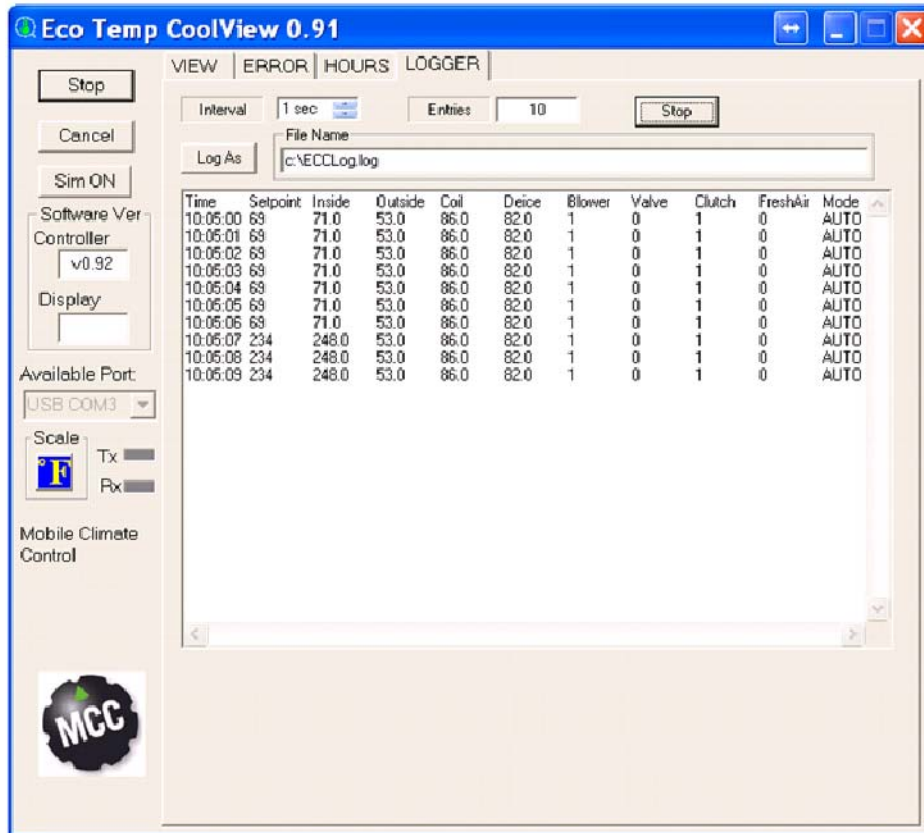
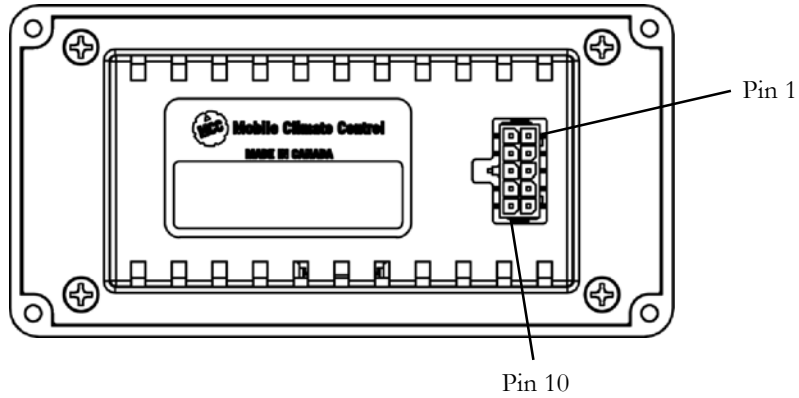

Figure 2-15 MCC Eco NG Coolview Data Logger

2.5.3 Eco NG Display Pin out Description



Pin out			
Pin	Function	Pin	Function
1	Power	6	J1939H
2	Dimmer	7	J1939 L
3	5V Output	8	J1939 Shield
4	Ground	9	Ground
5	RS485(Pos)	10	RS485(Neg)

Figure 2-16 MCC Eco NG Display Pin out

2.5.4 Eco NG Controller Pin out Description

Connector 1 (White)				Connector 1 (Gray)			
1	Digital Input 2	13	Vent Mode	25	De-ice Sensor	37	Digital Input 11
2	Digital Input 5	14	Condenser High Speed	26	ADI 4	38	Ground
3	Cool Mode	15	Condenser Low Speed	27	Digital Input 10	39	Ground
4	Defrost	16	High PSI	28	Digital Input 12	40	Ground
5	Condenser Med Speed	17	Valve 1	29	Digital Input 13	41	PWM 1 Analog
6	Test Mode	18	Inside Sensor	30	RS-485 (Pos)	42	PWM 2 Analog
7	Low PSI	19	Digital Input 0	31	RS-485 (Neg)	43	ADI 1
8	Valve 2	20	Digital Input 13	32	PWM 1	44	ADI 2
9	ADI 0	21	Off Mode	33	PWM 2	45	ADI 5
10	Digital Input 1	22	Heat Mode	34	Outside Sensor	46	Ground
11	Digital Input 4	23	Digital Input 7	35	ADI 3	47	Ground
12	Auto Mode	24	Digital Input 8	36	Digital Input 9	48	Ground

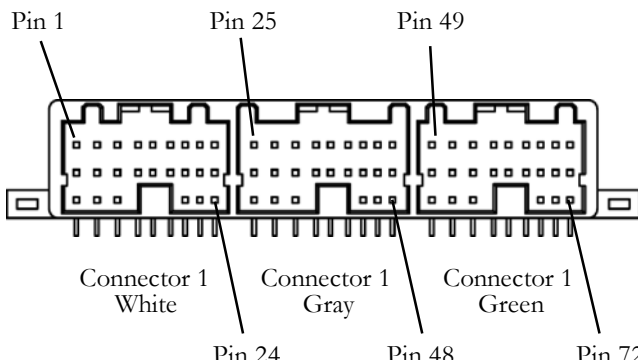

Pin 1 Pin 25 Pin 49

Connector 1 White Connector 1 Gray Connector 1 Green

Pin 24 Pin 48 Pin 72

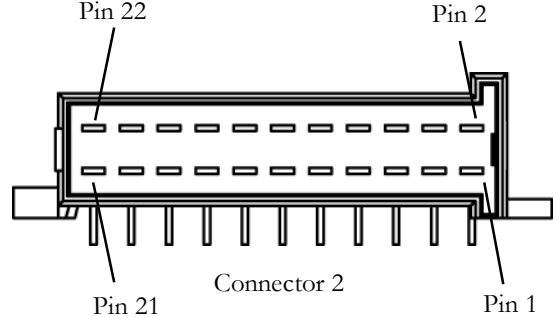

Pin 22 Pin 2

Pin 21 Connector 2 Pin 1

Connector 1 (Green)				Connector 2			
49	PWM 3 (Analog Out)	61	Not Used	1	Clutch	12	Digital Output 8
50	PWM 3	62	5V Out	2	Digital Output 0	13	Digital Output 9
51	PWM 4	63	5V Out	3	Digital Output 1	14	Power 2
52	J1939 Shield 1	64	5V Out	4	Clutch (High Current)	15	Digital Output 10
53	J1939 Low 1	65	5V Out	5	Digital Output 2	16	Not Used
54	J1939 High 1	66	5V Out	6	Power 1	17	Digital Output 11
55	J1939 Shield 2	67	Ground	7	Digital Output 3	18	Digital Output 12
56	J1939 Low 2	68	Ground	8	Digital Output 4	19	Valve 2 CCW
57	J1939 High 2	69	Ground	9	Digital Output 5	20	Boost Pump
58	PWM 4 Analog	70	Ground	10	Digital Output 6	21	Valve 2 CW
59	Valve 1 CW	71	Ground	11	Digital Output 7	22	Boost Pump (High Current)
60	Valve CCW	72	Ground				

Figure 2-17 MCC Eco NG Controller Pin out

SECTION 3

TROUBLESHOOTING

Table 3-1 General System Troubleshooting Procedures

INDICATION - TROUBLE	POSSIBLE CAUSES
3.1 System Will Not Cool	
Compressor will not run	Drive-Belt loose or defective Clutch coil defective Clutch malfunction Compressor malfunction
Electrical malfunction	Coach power source defective Circuit Breaker/safety device open
3.2 System Runs But Has Insufficient Cooling	
Compressor	Drive-Belt loose or defective Compressor valves defective
Refrigeration system	Abnormal pressures No or restricted evaporator air flow Expansion valve malfunction Restricted refrigerant flow Low refrigerant charge Service valves partially closed Safety device open
Restricted air flow	No evaporator air flow or restriction
Heating system	Heat valve stuck open
3.3 Abnormal Pressures	
High discharge pressure	Refrigerant overcharge Noncondensable in system Condenser motor failure Condenser coil dirty
Low discharge pressure	Compressor valve(s) worn or broken Low refrigerant charge
High suction pressure	Compressor valve(s) worn or broken
Low suction pressure	Suction service valve partially closed Filter-drier inlet valve partially closed Filter-drier partially plugged Low refrigerant charge Expansion valve malfunction Restricted air flow
Suction and discharge pressures tend to equalize when system is operating	Compressor valve defective
3.4 Abnormal Noise Or Vibrations	
Compressor	Loose mounting hardware Worn bearings Worn or broken valves Liquid slugging Insufficient oil Clutch loose, rubbing or is defective Drive-Belt cracked, worn or loose Dirt or debris on fan blades

Table 3-1 General System Troubleshooting Procedures - Continued

INDICATION - TROUBLE	POSSIBLE CAUSES
3.4 Abnormal Noise Or Vibrations - Continued	
Condenser or evaporator fans	Loose mounting hardware Defective bearings Blade interference Blade missing or broken
3.5 No Evaporator Air Flow Or Restricted Air Flow	
Air flow through coil blocked	Coil frosted over Dirty coil Dirty filter
No or partial evaporator air flow	Motor(s) defective Motor brushes defective Evaporator fan loose or defective Fan damaged Return air filter dirty Icing of coil Fan relay(s) defective Safety device open Fan rotation incorrect
3.6 Expansion Valve Malfunction	
Low suction pressure with high superheat	Low refrigerant charge Wax, oil or dirt plugging valve orifice Ice formation at valve seat Power assembly failure Loss of bulb charge Broken capillary tube
Low superheat and liquid slugging in the compressor	Bulb is loose or not installed. Superheat setting too low Ice or other foreign material holding valve open
Side to side temperature difference (Warm Coil)	Wax, oil or dirt plugging valve orifice Ice formation at valve seat Power assembly failure Loss of bulb charge Broken capillary
3.7 Heating Malfunction	
Insufficient heating	Dirty or plugged heater core Coolant solenoid valve(s) malfunctioning or plugged Low coolant level Strainer(s) plugged Hand valve(s) closed Water pumps defective Auxiliary Heater malfunctioning.
No Heating	Coolant solenoid valve(s) malfunctioning or plugged Controller malfunction Pump(s) malfunctioning Safety device open
Continuous Heating	Coolant solenoid valve stuck open

SECTION 4

SERVICE

 **WARNING**

Be sure to observe warnings listed in the safety summary in the front of this manual before performing maintenance on the hvac system.

 **WARNING**

Read the entire procedure before beginning work. Park the coach on a level surface, with parking brake applied. Turn main electrical disconnect switch to the off position.

NOTE

To avoid damage to the earth's ozone layer, use a refrigerant recovery system whenever removing refrigerant. When working with refrigerants you must comply with all local government environmental laws.

4.1 MAINTENANCE SCHEDULE

SYSTEM		SYSTEM
ON	OFF	
a. Daily Maintenance		
X	X	Pre-trip Inspection - after starting Check tension and condition of V-belt
b. Weekly Inspection		
X	X X X	Perform daily inspection Check condenser, evaporator coils and air filters for cleanliness Check refrigerant hoses and compressor shaft seal for leaks Feel filter-drier for excessive temperature drop across drier
c. Monthly Inspection and Maintenance		
	X X X X X	Perform weekly inspection and maintenance Clean evaporator drain pans and hoses Check wire harnesses for chafing and loose terminals Check fan motor bearings Check compressor mounting bolts for tightness Check fan motor brushes

4.2 OPENING TOP COVER (EVAPORATORS)

To open the evaporator assembly cover do the following: (See Figure 4-1.)

- a. Remove all 4 of the (5/16" x 18 x 1") retaining bolts at front end of cover.
- b. Grasp the front cover section under the bottom edge and lift up. Cover will pivot on the 2 hinges at rear of cover.

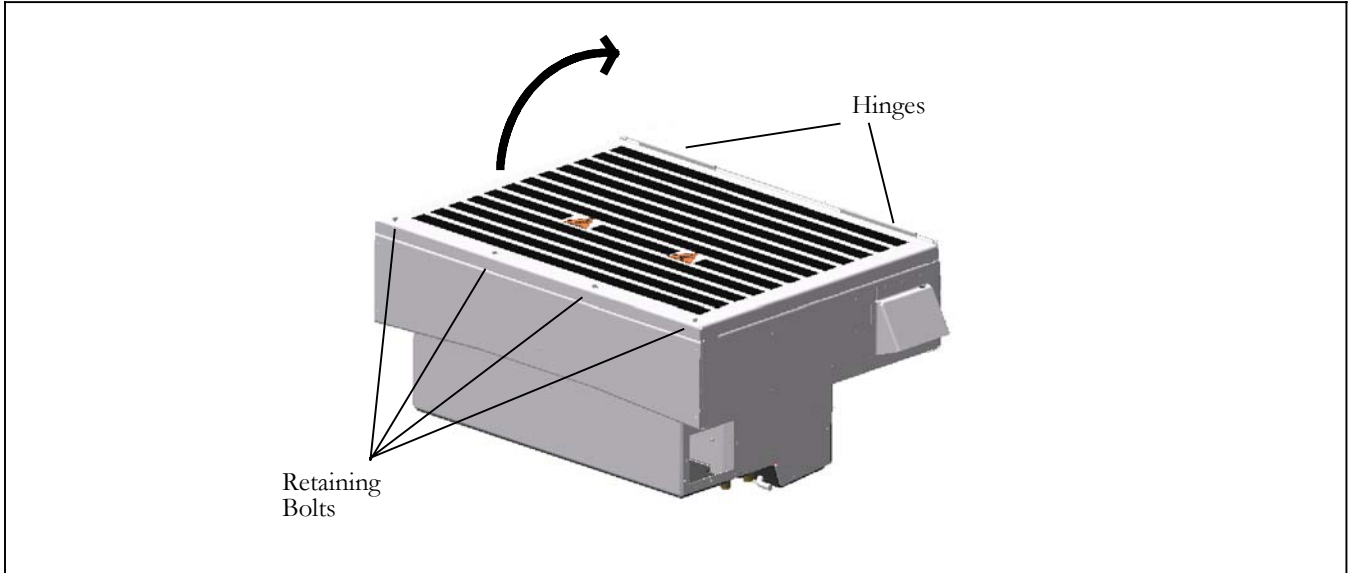

Figure 4-1 Opening Top Cover (Evaporator)

4.3 REMOVING TOP COVERS (CONDENSER)

The condenser cover consist of the condenser fan deck and 2 side covers.

- a. To remove the side covers, remove the 14- (5/16" x 18 x 1") from each cover and carefully lift covers off. (Item 1 & 2 in Figure 4-2)
- b. To remove the fan deck, remove the 3- (5/16" x 18 x 1") from each end of fan deck assembly, and carefully lift and unplug fan assemblies from the harness. (Item 3 in Figure 4-2)

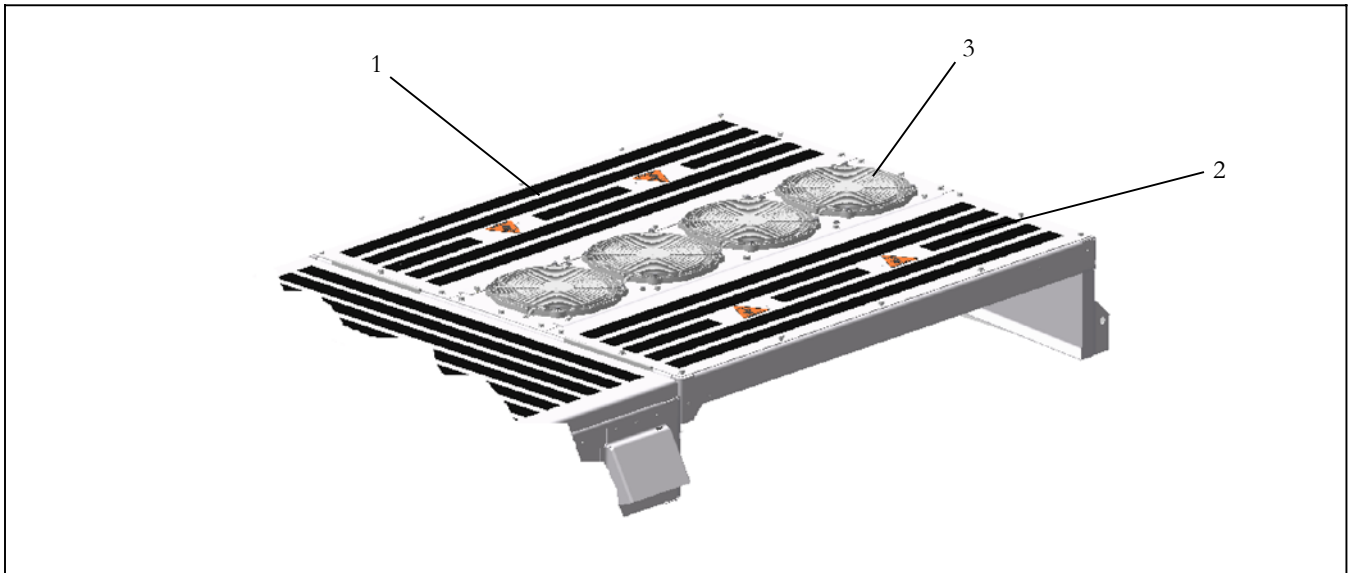

Figure 4-2 Removing Top Covers (Condenser)

4.4 SUCTION AND DISCHARGE SERVICE VALVES

The suction and discharge service valves (Figure 4-3) are provided with a double seat and a gauge port, which allows servicing of the compressor and refrigerant lines.

Turning the valve stem counterclockwise (all the way out) will *backseat* the valve to open the line to the compressor and close off the gauge port. In normal operation, the valve is backseated to allow full flow through the valve. The valve should always be backseated before removing the gauge port cap.

Turning the valve stem clockwise (all the way forward) will *frontseat* the valve to isolate the compressor line and open the gauge port.

To measure suction or discharge pressure, midseat the valve by opening the valve clockwise 1/4 to 1/2 turn. With the valve stem midway between frontseated and backseated positions, the suction or

discharge gauge port is open to both the compressor and the line.

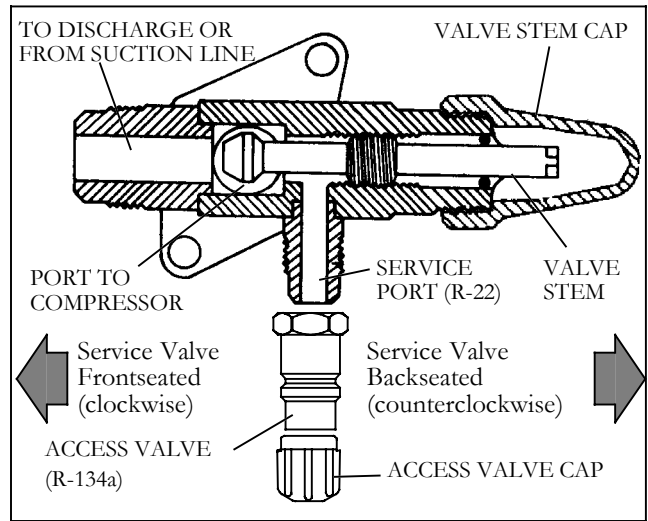

Figure 4-3 Suction or Discharge Service Valve

4.4.1 Installing R-134a Manifold Gauge Set

A R-134a manifold gauge/hose set with self-sealing hoses is required for service of models covered within this manual. To perform service using the manifold gauge/hose set, do the following:

a. Preparing Manifold Gauge/Hose Set For Use

1. If the manifold gauge/hose set is new or was exposed to the atmosphere it will need to be evacuated to remove contaminants and air as follows:
2. Back seat (turn counterclockwise) both field service couplers (see Figure 4-4) and midseat both hand valves.
3. Connect the yellow hose to a vacuum pump and an R-134a cylinder.
4. Evacuate to 10 inches of vacuum and then charge with R-134a to a slightly positive pressure of 1.0 psig.
5. Front seat both manifold gauge set hand valves and disconnect from cylinder. The gauge set is now ready for use.

b. Connecting Manifold Gauge/Hose Set

To connect the manifold gauge/hose set for reading pressures, do the following:

1. Remove service valve stem cap and check to make sure it is backseated. Remove access valve cap.
2. Connect the field service coupler (see Figure 4-4) to the access valve.
3. Turn the field service coupling knob clockwise, which will open the system to the gauge set.
4. Read system pressures.
5. Repeat the procedure to connect the other side of the gauge set.

c. Removing the Manifold Gauge Set

1. While the compressor is still ON, backseat the high side service valve.
2. Midseat both hand valves on the manifold gauge set and allow the pressure in the manifold gauge set to be drawn down to low side pressure. This returns any liquid that may be in the high side hose to the system.

⚠ CAUTION

To prevent trapping liquid refrigerant in the manifold gauge set be sure set is brought to suction pressure before disconnecting.

3. Backseat the low side service valve. Backseat both field service couplers and frontseat both manifold set hand valves. Remove the couplers from the access valves.
4. Install both service valve stem caps and access valve caps (finger-tight only).

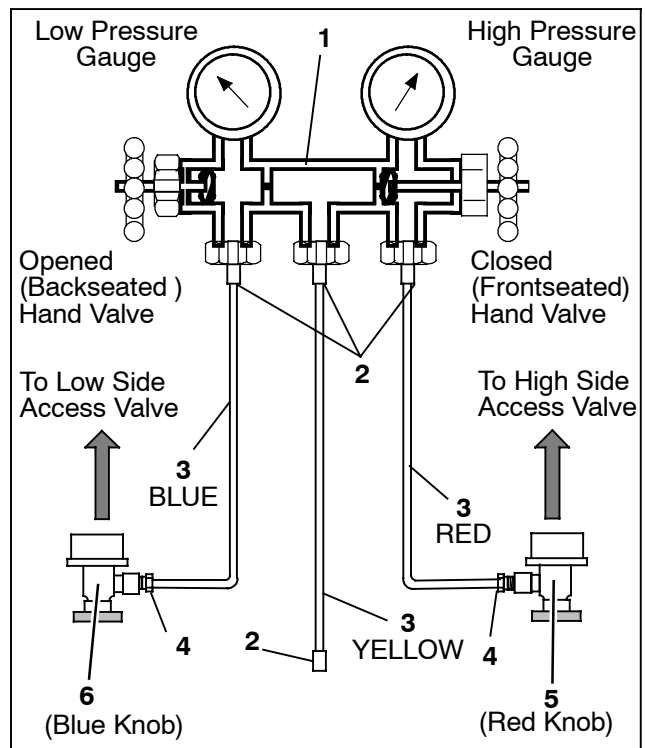

1. Manifold Gauge Set
2. Hose Fitting (0.5-16 Acme)
3. Refrigeration and/or Evacuation Hose (SAE J2196/R-134a)
4. Hose Fitting w/O-ring (M14 x 1.5)
5. High Side Field Service Coupler
6. Low Side Field Service Coupler

Figure 4-4 Manifold Gauge Set (R-134a)

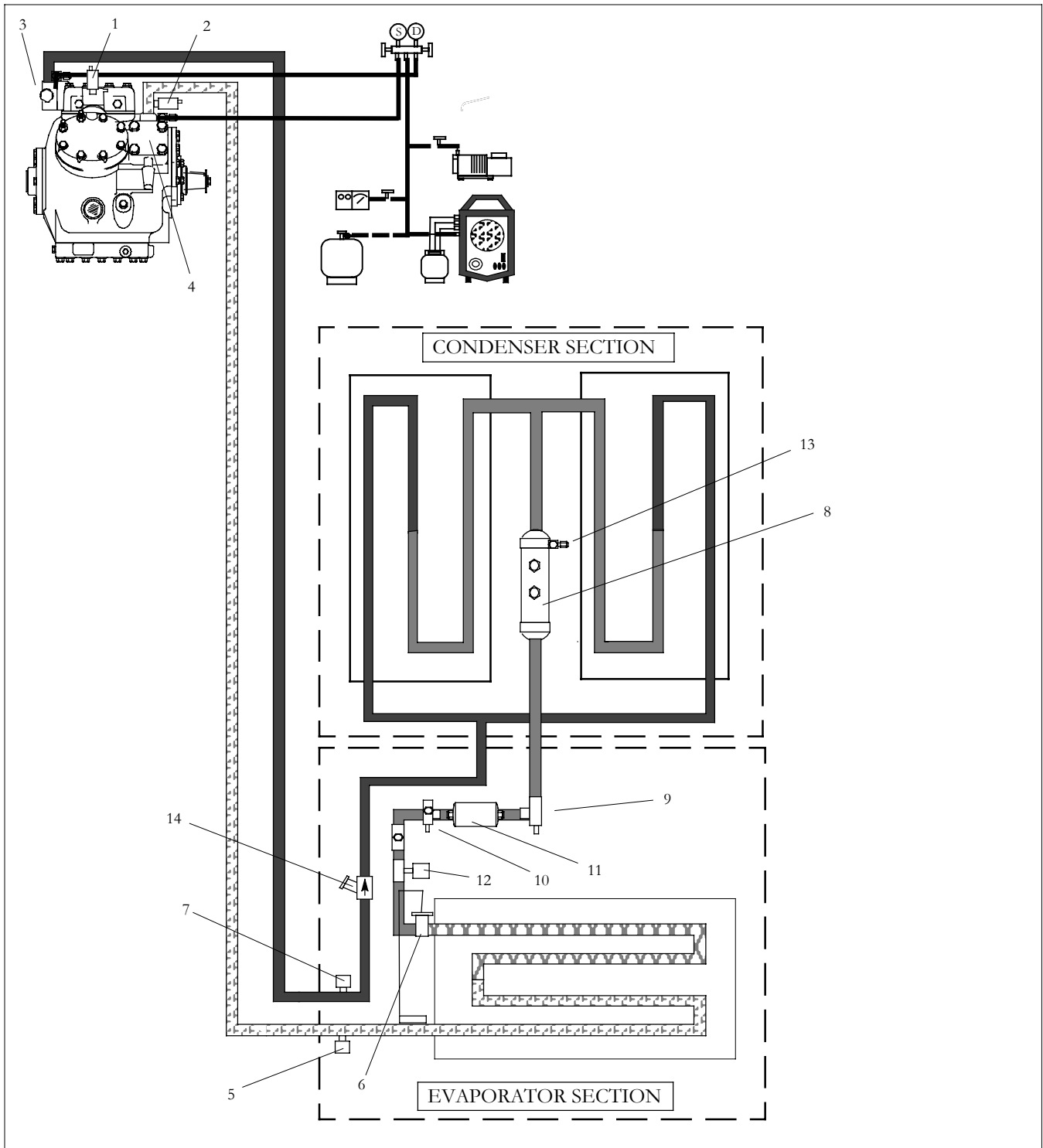

- | | |
|----------------------------------|---|
| 1. High Pressure Switch | 8. Receiver Tank |
| 2. Low Pressure Switch | 9. Filter Drier Service Valve (Inlet) |
| 3. Discharge Service Valve | 10. Filter Drier Service Valve (Outlet) |
| 4. Suction Service Valve | 11. Filter Drier |
| 5. Pressure Transducer (SPT) | 12. Liquid Line Solenoid Valve |
| 6. Thermal Expansion Valve (IXV) | 13. Fusible Plug |
| 7. Pressure Transducer (DPT) | 14. Discharge Check Valve |

Figure 4-5 Service Connections



4.4.2 SYSTEM PUMP DOWN FOR LOW SIDE REPAIR

To service or replace the thermostatic expansion valves, filter drier, suction line or liquid line solenoid valve. pump the refrigerant to the condenser and receiver as follows:

- a. Install manifold gauge set to compressor suction & discharge valve service ports (items 4 & 3). Refer to Figure 4-5.
- b. Frontseat the filter-drier inlet service valve (9) by turning clockwise. Disconnect suction pressure transducer (5) electrical connector, install a jumper on the compressor mounted low pressure switch (2) (electrical connector on harness).
- c. Start the system and run in cooling. Stop the unit when suction reaches 0 psig (0 Bar).
- d. **Disconnect the compressor clutch wire to disable clutch operation.** Frontseat the compressor discharge service valve (3) to trap refrigerant in the high side of the system between the compressor discharge service valve and the filter-drier inlet valve. Wait 5 minutes to verify that system remains at approximately 0 psig (0 Bar). If system pressure rises above 0 psig (0 Bar), open the compressor discharge service valve, re-connect the compressor clutch wiring and repeat steps c and d until the system remains at 0 psig (0 Bar).
- e. Service or replace necessary components.
- f. Leak check connections on the low side of system by adding nitrogen through the suction service port. Replace filter-drier (11). Refer to paragraph 4.5.
- g. Energize the Liquid Line Solenoid Valve (LSV) (12) using an external power source (24 VDC).
- h. Using refrigerant hoses designed for vacuum service, evacuate and dehydrate the low side of the system by connecting a vacuum pump to the center hose connection of manifold gauge set. Verify the compressor suction service valve is mid-seated. Open (backseat) the manifold suction and discharge service valves. Evacuate system to 500 microns. Close off vacuum pump valve and stop pump. Wait 5 minutes to verify that vacuum holds. If vacuum holds below 1000 microns, isolate the micron gauge from system to prevent exposure to pressure.
- i. Open compressor suction and discharge service valves and inlet service valve of filter drier.
- j. Disconnect external 24 VDC to liquid solenoid valve (14).
- k. Re-connect compressor clutch, low pressure switch and low pressure transducer electrical connectors.
- l. Run and check refrigerant level. Refer to paragraph 4.7.



4.4.3. Removing Entire System Charge

NOTES

It is recommended that the Filter/Drier be replaced after opening the refrigeration system for any repair.



WARNING

Use of an electro-magnetic valve as a means of positive shutoff for service is not recommended or good service practice.



CAUTION

For Safety, the bus and A/C system should be OFF, and lockout/tag out procedures should be implemented.

To remove the entire refrigerant charge for system component repair, do the following:

- Connect a manifold gauge set to the system as shown in Figure 4-5.
- Connect a reclaimer to the center manifold gauge set connection.
- Energize the Liquid Line Solenoid Valve (LSV) (Item 12 in Figure 4-5) using an external power source (24 VDC).
- Recover refrigerant in accordance with reclaimer manufacturers instructions.
- After repair is completed, a leak check should be performed prior to system evacuation/dehydration and charging. Refer to paragraph 4.5.

4.5 REFRIGERANT LEAK CHECK

A refrigerant leak check should always be performed after the system has been opened to replace or repair a component. To check for leaks in the refrigeration system, perform the following procedure:

NOTE

It is emphasized that only the correct refrigerant should be used to pressurize the system. Use of any other refrigerant will contaminate the system.

- Ensure the service valves are open.
- Energize the Liquid Line Solenoid Valve (LSV) (Item 12 in Figure 4-5) using an external power source (24 VDC).
- If system is without refrigerant, charge system with refrigerant vapor to build up pressure to approximately 30 PSIG (R-134a).
- Add sufficient nitrogen to raise system pressure to 150 to 200 psig (10.21 to 13.61 bar).
- Check for leaks. The recommended procedure for finding leaks in a system is with an electronic leak detector. Testing joints with soap suds is satisfactory and may be necessary under conditions when an electronic leak detector will not function correctly.
- Remove test gas and replace filter-drier.
- Evacuate and dehydrate the system. Refer to paragraph 4.6.
- Charge the unit. Refer to Section 4.7.

4.6 EVACUATION AND DEHYDRATION

4.6.1 General

The presence of moisture in a refrigeration system can have many undesirable effects. The most common are copper plating, acid sludge formation, “freezing-up” of metering devices by free water, and formation of acids, resulting in metal corrosion. A triple evacuation (Refer to paragraph 4.6.4) should be performed after a major system repair (compressor, evaporator, or condenser replacement). A one time evacuation (Refer to paragraph 4.6.3) should take place after a minor system repair (replacement of a solenoid valve or a filter drier).

4.6.2 Preparation

NOTE

Using a compound gauge for determination of vacuum level is not recommended because of its inherent inaccuracy.

- Evacuate and dehydrate only after pressure leak test. Refer to paragraph 4.5.



- b. Essential tools to properly evacuate and dehydrate any system include a good two stage vacuum pump with a minimum of 6 cfm (10.2 m³/hr) volume displacement.
- c. Keep the ambient temperature above 60°F (15.6°C) to speed evaporation of moisture. If ambient temperature is lower than 60°F (15.6°C), ice may form before moisture removal is complete.

4.6.3 Procedure for Evacuation and Dehydrating System (One Time Evacuation)

- a. Remove refrigerant using a refrigerant recovery system. Refer to paragraph 4.4.3.
- b. The recommended method is connecting lines (refrigerant hoses designed for vacuum service) as shown in Figure 4-5.
- c. Energize the Liquid Line Solenoid Valve (LSV) (Item 12 in Figure 4-5) using an external power source (24 VDC).
- d. Start vacuum pump. Slowly open valves halfway and then open vacuum gauge valve.
- e. Evacuate unit until vacuum gauge indicates 500 microns Hg vacuum.
- f. Close off pump valve and stop pump. Wait five minutes to see if vacuum holds below 1000 microns.
- g. Close vacuum gauge valve to prevent damage to vacuum gauge. Vacuum gauges should never be exposed to positive pressure to avoid damage or affect the vacuum gauge calibration.
- h. Charge system. Refer to paragraph 4.7.3.

4.6.4 Procedure for Evacuation and Dehydrating System (Triple Evacuation)

- a. Remove refrigerant using a refrigerant recovery system. Refer to paragraph 4.4.3.
- b. The recommended method is connecting lines (refrigerant hoses designed for vacuum service) as shown in Figure 4-5 .
- c. Energize the Liquid Line Solenoid Valve (LSV) (Item 12 in Figure 4-5) using an external power source (24 VDC).
- d. Start vacuum pump. Slowly open valves halfway and then open vacuum gauge valve.
- e. Evacuate unit until vacuum gauge indicates 2000 microns Hg vacuum. Close gauge valve, vacuum pump valve, and stop vacuum pump.

- f. Break the vacuum with nitrogen. Raise system pressure to approximately 2 psig.
- g. Purge the nitrogen from the system.
- h. Repeat steps d. thru g. one time.
- i. Start vacuum pump and open all valves. Dehydrate unit to 500 microns Hg vacuum.
- j. Close off pump valve , and stop pump. Wait five minutes to see if vacuum holds.
- k. Close vacuum gauge valve to prevent damage to vacuum gauge. Vacuum gauges should never be exposed to positive pressure to avoid damage or affect the vacuum gauge calibration.
- l. Charge system. Refer to paragraph 4.7.3.

4.7 CHECKING AND ADDING REFRIGERANT TO SYSTEM

4.7.1 Checking Refrigerant Charge By Pressures

For the purpose of checking refrigerant pressures to determine if the approximate charge level is correct, the following conditions and method can be used:

- a. Install Manifold Gauge set as described in Paragraph 4.4.1
- b. Coach engine operating at high idle.
- c. Unit operating fully loaded in cool mode for 15 minutes.
- d. Compressor discharge (head) pressure to 150 PSIG (R-134a). (It may be necessary to heat the coach to provide sufficient heat load).
- e. Under the above conditions, the “Rule of Thumb” method can be used as a reference for proper charge level. See Figure 4-6.

“Rule of Thumb”
Air Conditioning System Pressures

For Discharge Pressure

Condenser Inlet Temperature	_____	_ F
Plus (Constant)	40	_ F
Equals	_____	_ F
P/T Chart Temperature	_____	PSIG

For Suction Pressure

Evap. Return Air Temperature	_____	_ F
Minus (Constant)	30	_ F
Equals	_____	_ F
P/T Chart Temperature	_____	PSIG

Figure 4-6 Rule of Thumb

4.7.2 Checking Refrigerant Charge By Receiver Sight Glasses

For the purpose of checking refrigerant sight glasses to determine if the approximate charge level is correct, the following conditions and method can be used:

- a. Unit operating fully loaded in cool mode for 15 minutes.
- b. Compressor discharge (head) pressure to 150 PSIG (R-134a). (It may be necessary to heat the coach to provide sufficient heat load).
- c. Under the above conditions, the system is charged properly when liquid refrigerant is visible in the lower sight glass located on receiver tank, with no refrigerant visible in the upper sight glass.

4.7.3 Adding Full Charge

- a. Install manifold gauge set at the compressor suction service valve and discharge service port. See figure Figure 4-5.
- b. Leak check the system. Refer to paragraph 4.5.
- c. Evacuate and dehydrate system. Refer to paragraph 4.6.
- d. Add manifold gauge set at filter drier outlet valve (item 10 in Figure 4-7). Connect center hose of gauge set to appropriate refrigerant cylinder and high side hose to filter drier outlet valve service port. Purge air from hoses.
- e. Note weight of refrigerant and cylinder.
- f. While system is in a deep vacuum, add liquid refrigerant to the high side of system through the filter drier outlet valve. Monitor refrigerant weight being added using a refrigerant scale.
- g. When correct charge has been added (refer to paragraph 1.3), close cylinder valve.
- h. Check charge level in accordance with the procedures of paragraph 4.7.1.

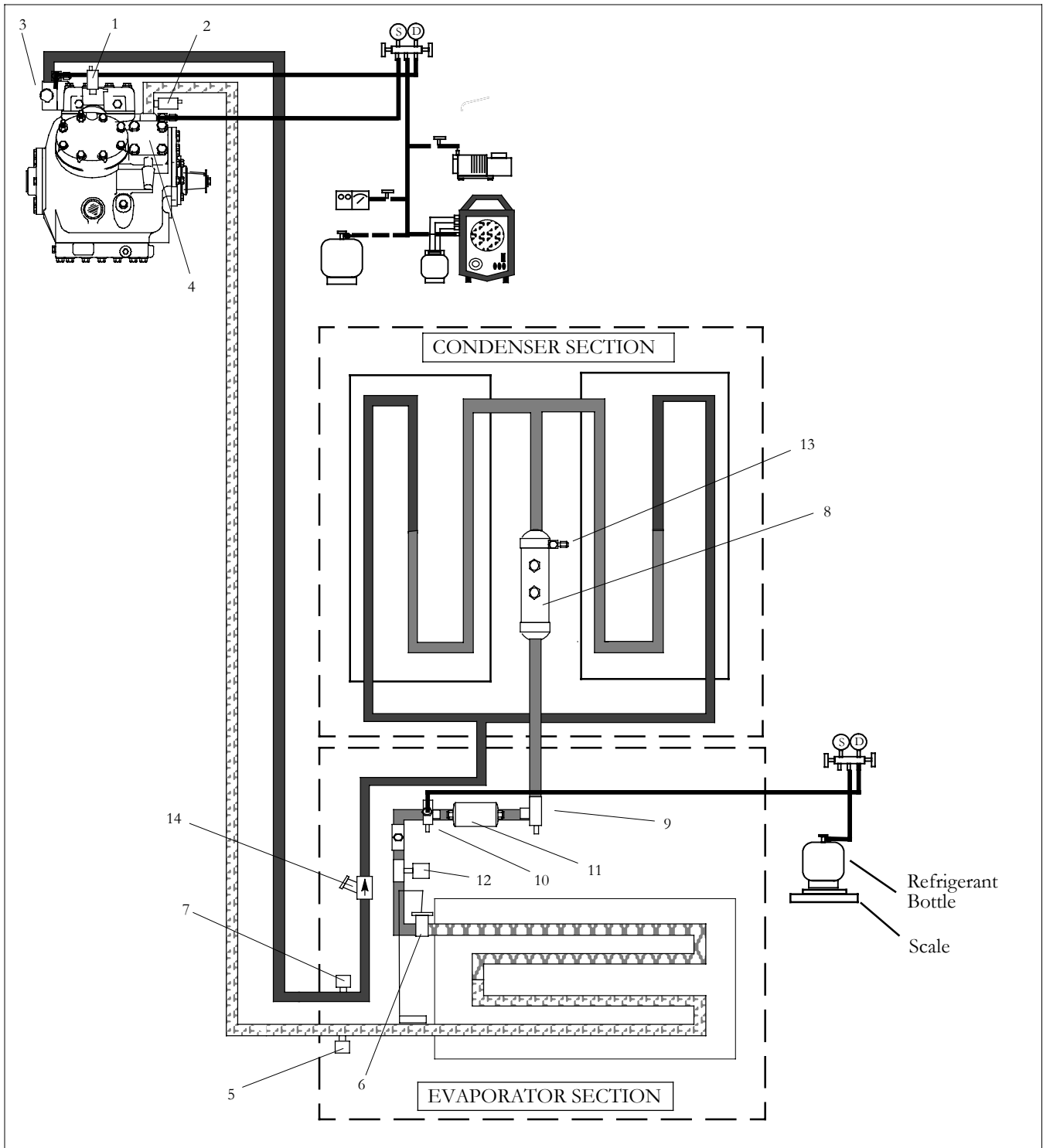

- | | |
|----------------------------------|---|
| 1. High Pressure Switch | 8. Receiver Tank |
| 2. Low Pressure Switch | 9. Filter Drier Service Valve (Inlet) |
| 3. Discharge Service Valve | 10. Filter Drier Service Valve (Outlet) |
| 4. Suction Service Valve | 11. Filter Drier |
| 5. Pressure Transducer (SPT) | 12. Liquid Line Solenoid Valve |
| 6. Thermal Expansion Valve (TXV) | 13. Fusible Plug |
| 7. Pressure Transducer (DPT) | 14. Discharge Check Valve |

Figure 4-7 Service Connections

4.7.4 Adding Partial Charge

- a. Check charge level in accordance with the procedures of paragraph 4.7.2.
- b. Install manifold gauge set at the compressor suction service valve and discharge service port. See figure Figure 4-5.
- c. Place appropriate refrigerant cylinder on scale. Prepare to charge vapor refrigerant by connecting charging hose from container to center connection on gauge manifold. Purge air from hoses.
- d. Run the unit in the cool mode for 15 minutes with minimum of 150 psig (R134a). It may be necessary to heat coach to provide adequate heat load. With the suction service valve midseated, open the refrigerant cylinder valve and add vapor charge until the refrigerant level appears in the lower receiver sight glass. If it is not at the proper level, add or remove refrigerant to bring it to the proper level. *Refrigerant level should not appear in the upper sight glass, as this would indicate an overcharge.*
- e. Backseat the suction service valve. Close the vapor valve on the refrigerant cylinder and note weight. Remove the manifold gauge set and replace all valve caps.

4.8 CHECKING SYSTEM FOR NON-CONDENSIBLES

To check for noncondensibles, proceed as follows:

- a. Stabilize system to equalize pressure between the suction and discharge side of the system.
- b. Check temperature at the condenser and receiver.
- c. Check pressure at the filter-drier inlet service valve.
- d. Check saturation pressure as it corresponds to the condenser/receiver temperature using the Temperature-Pressure Chart, Table 4-3.
- e. If gauge reading is 3 psig (0.20 bar) or more than the saturation pressure in step d, noncondensibles are present.
- f. Remove refrigerant using a refrigerant recovery system.
- g. Evacuate and dehydrate the system. Refer to paragraph 4.6.4.
- h. Charge the unit. Refer to paragraph 4.7.3.

4.9 CHECKING AND REPLACING HIGH OR LOW PRESSURE SWITCH

WARNING

Do not use a nitrogen cylinder without a pressure regulator

WARNING

Do not use oxygen in or near a refrigeration system as an explosion may occur.

- a. Disconnect wiring and remove switch from unit. All units are equipped with a schrader valve at the pressure switch connections.
- b. Connect switch to a cylinder of dry nitrogen. See Figure 4-8.

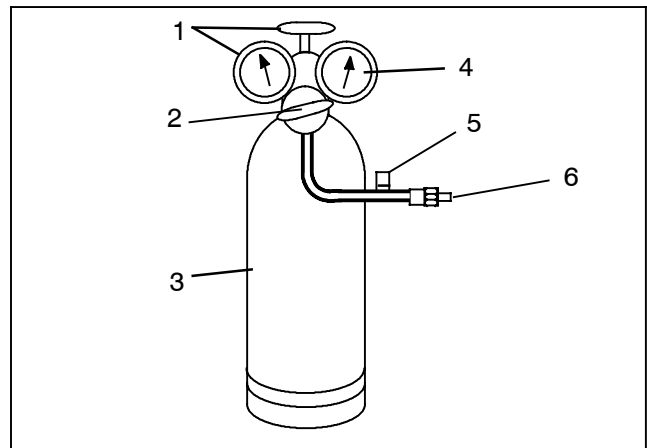

1. Cylinder Valve and Gauge
2. Pressure Regulator
3. Nitrogen Cylinder
4. Pressure Gauge (0 to 400 psig = 0 to 27.22 bar)
5. Bleed-Off Valve
6. 1/4 inch Connection

Figure 4-8 Checking High Pressure Switch

- c. Connect an ohmmeter across switch terminals.
- d. Set nitrogen pressure regulator higher than the upper switch setting. (refer to paragraph 1.3.)
- e. For a high pressure switch, close cylinder valve and open bleed-off valve. Open cylinder valve and slowly close bleed-off valve. The switch should open, (no continuity) within required cut out tolerance. Close cylinder valve and release pressure through the bleed-off valve. As pressure drops,



switch should close, (continuity) within required cut in tolerance.

- f. For a low pressure switch, close cylinder valve and bleed-off valve. Open cylinder valve to bring pressure above the cutout setting. Close the cylinder valve and slowly open bleed-off valve. The switch should open, (no continuity) within required cut out tolerance. Open cylinder valve and increase pressure by closing the bleed-off valve. As pressure increases, switch should close, (continuity) within required cut in tolerance.
- g. Replace or re-install switch (as required) and re-connect wiring.

4.10 FILTER-DRIER

4.10.1 To Check Filter-Drier

The filter-drier (see Figure 4-9) must be changed if the drier is partially restricted or service has been performed on the refrigerant system. Check for a restriction by feeling the inlet and outlet lines of the filter-drier. If the outlet side feels cooler than the inlet side, then the filter-drier should be changed.

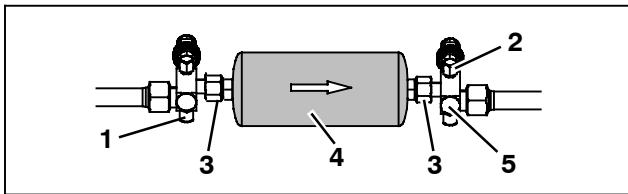

- 1. Filter-Drier Inlet Service Valve
- 2. Valve Service Port
- 3. Hex Nut
- 4. Filter-Drier
- 5. Filter-Drier Outlet Service Valve

Figure 4-9 Filter-Drier Removal

4.10.2 To Replace Filter-Drier



Use of an electro-magnetic valve as a means of positive shutoff for service is not recommended for safety, or good service practice.

- a. Perform a system low side pump down. Refer to paragraph 4.4.2.
- b. Front seat the filter drier outlet valve to isolate filter drier.

- c. Lock out/Tag out the bus electrical system to prevent unit operation.
- d. Using wrenches to back up the service valves, slowly loosen hex nuts retaining the filter drier.



The filter-drier may contain liquid refrigerant. Slowly loosen the ORS hex nuts to avoid refrigerant contact with exposed skin or eyes.

- e. Place a new filter-drier near the unit for immediate installation.
- f. Loosen or remove clamps securing the filter-drier.
- g. Remove the filter-drier.
- h. Remove seal caps from the new filter-drier. Apply a light coat of mineral oil to the O-Rings and seat in the grooves of the filter-drier.
- i. Assemble the new filter-drier to lines ensuring that the arrow on the body of the filter-drier points in the direction of the refrigerant flow (refrigerant flows from the condenser to the evaporator), and that the O-Rings have remained in place. Finger tighten ORS hex nuts.
- j. Tighten the filter-drier ORS hex nuts using two open end wrenches.
- k. Leak check filter drier connections with nitrogen by adding through filter drier service valve ports.
- l. Remove nitrogen and evacuate filter drier using filter drier service ports.
- m. Open filter drier service ports and restore electrical power to unit.

4.11 SERVICING THE LIQUID LINE SERVICE VALVE

The Liquid line solenoid valve (Figure 4-10) requires no maintenance unless a malfunction to the internal parts or coil occurs. This may be caused by foreign material such as: dirt, scale, or sludge in the refrigeration system, or improper voltage to the coil.

There are only three possible valve malfunctions: coil burnout, failure to open, or failure to close.

Coil burnout may be caused by the following:

- 1 Improper voltage.
- 2 Continuous over-voltage, more than 10% or under-voltage of more than 15%.

- 3 Incomplete magnet circuit due to the omission of the coil housing or plunger.
- 4 Mechanical interface with movement of plunger which may be caused by a deformed enclosing tube.

Failure to open may be caused by the following:

- 1 Coil burned out or an open circuit to coil connections.
- 2 Improper voltage.
- 3 Defective plunger or deformed valve body assembly.

Failure to close may be caused by the following:

- 1 Defective plunger or deformed valve body assembly.
- 2 Foreign material in the valve.

4.11.1 Coil Replacement

- a. It is not necessary to remove the refrigerant charge from the system.
- b. Place main battery disconnect switch in OFF position and lock.
- c. Disconnect wire leads to coil.
- d. Remove coil retaining screw.
- e. Lift coil from enclosing tube and replace.
- f. With the coil installed replace the retaining screw.
- g. Connect wire leads and test operation

4.11.2 Internal Part Replacement

- a. Perform a low side pump down on system. Refer to paragraph 4.4.2.
- b. Carefully loosen enclosing tube assembly and ensure no pressure remains within the valve. Disassemble valve and replace defective parts.
- c. Assemble valve and leak check. Refer to paragraph 4.5
- d. Evacuate/Dehydrate low side of system. Refer to paragraph .
- e. Open valves and test operation..

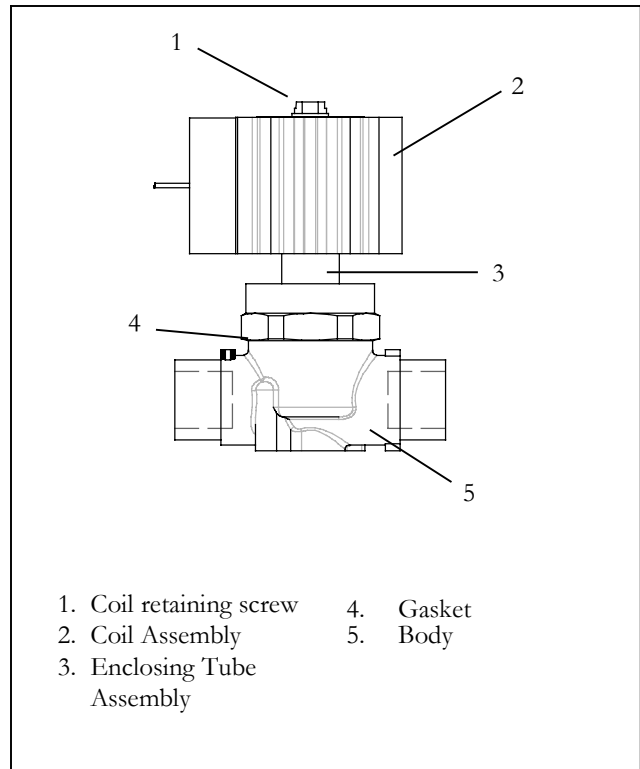

Figure 4-10 Liquid Line Solenoid Valve

4.11.3 Replace Entire LLS Valve

- a. Perform a low side pump down on system. Refer to paragraph 4.4.2.
- b. Remove coil assembly and enclosing tube assembly. Refer to paragraph 4.11.1.
- c. Un-braze valve body from piping, while using an inert gas purge to avoid system contamination from carbon due to heat and oxidation.
- d. Clean tubing to accept new valve body.
- e. Disassemble enclosing tube assembly and components from new valve. Install new valve body by brazing body to piping while using inert gas purge to protect system contamination.
- f. Once valve body has cooled, re-install enclosing tube assembly and components on new valve.
- g. Install new filter-drier.
- h. Leak check connections. Refer to paragraph 4.5, excluding the replacement of filter drier referenced in step (e).
- i. Evacuate/Dehydrate low side of system. Refer to paragraph 4.6.
- j. Replace coil assembly and test operation.

4.12 THERMOSTATIC EXPANSION VALVE

The thermostatic expansion valve (Figure 4-10) is an automatic device which maintains constant superheat of the refrigerant gas leaving the evaporator regardless of suction pressure. The valve functions are: (a) automatic control of refrigerant flow to match the evaporator load and (b) prevention of liquid refrigerant entering the compressor. Unless the valve is defective, it seldom requires any maintenance.

4.12.1 Valve Replacement

- a. Perform a low side pump down on system. Refer to paragraph 4.4.2.
- b. Remove insulation from expansion valve and bulb.
- c. Loosen retaining straps holding bulb to suction line and detach bulb from the suction line.
- d. Un-braze valve body and equalizer line from piping, while using an inert gas purge to avoid system contamination from carbon due to heat and oxidation.
- e. Clean tubing to accept new valve body.
- f. Reinstall the new valve assembly into the unit in reverse order.
- g. Leak check valve assembly. Refer to paragraph 4.5
- h. The thermal bulb is installed below the center of the suction line (four or eight o'clock position). This area must be clean to ensure positive bulb contact. Strap thermal bulb to suction line. Ensure that retaining straps are tight and renew insulation.
- i. Evacuate/Dehydrate system. Refer to paragraph 4.6.
- j. Open isolation valves
- k. Run the coach for approximately 30 minutes on fast idle.
- l. Check refrigerant level. Refer to paragraph 4.7.1.
- m. Check superheat. Refer to paragraph 4.12.2.

4.12.2 Superheat Measurement

NOTE

All readings must be taken from the TXV bulb location and out of the direct air stream.

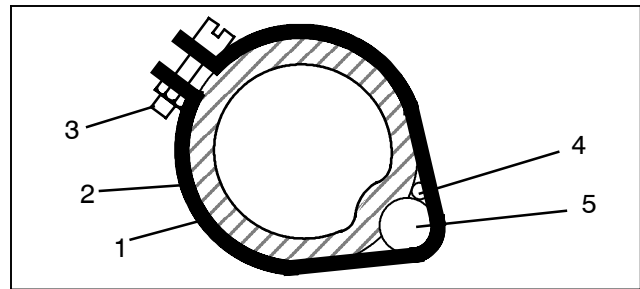

- | | |
|-----------------------------------|---|
| 1. Suction Line
(section view) | 4. Thermocouple |
| 2. TXV Bulb Clamp | 5. TXV Bulb (Shown
in the 4'clock
position) |
| 3. Nut & Bolt (clamp) | |

Figure 4-11 Thermostatic Expansion Valve Bulb and Thermocouple

- a. Remove Presstite insulation from expansion valve bulb and suction line.
- b. Loosen one TXV bulb clamp and make sure area under clamp is clean.
- c. Place temperature thermocouple in contact with the suction tube and parallel to the TXV bulb, and then secure loosened clamp making sure both bulb and thermocouple are firmly secured to suction line. See Figure 4-11. Reinstall insulation around the bulb.
- d. Connect an accurate low pressure gauge to the low pressure port (Figure 1-2).
- e. Start bus and run on fast idle until unit has stabilized, about 20 to 30 minutes.

NOTE

When conducting this test, the suction pressure must be at least 6 psig (0.41 bar) below the expansion valve maximum operating pressure (MOP) if applicable.

- f. From the temperature/pressure chart (Table 4-3), determine the saturation temperature corresponding to the evaporator outlet pressure.
- g. Note the temperature of the suction gas at the expansion valve bulb. Subtract the saturation temperature from this temperature. The difference is the superheat of the suction gas.
- h. The superheat may cycle from a low to high reading. Monitor the superheat taking readings every 3-5 minutes for a total of 5-6 readings. Calculate the superheats, add the readings and divide by the number of readings taken to determine average superheat. Refer to paragraph 1.3 for superheat setting.



- i. If superheat is not within tolerance, replace the valve.

4.13 REPLACING EVAPORATOR RETURN AIR FILTERS

The evaporator return air filters are located in the return air section in ceiling. Access to the filters is accomplished by opening the return air cover.

The filters should be checked for cleanliness periodically depending on operating conditions. A dirty filter will restrict air flow over the evaporator coil which may cause insufficient cooling or heating and possible frost buildup on the coil. To remove the filters, do the following.

4.14 COMPRESSOR MAINTENANCE

4.14.1 Shaft Seal Reservoir

Compressor is fitted with a shaft seal reservoir equipped with a clear tube for checking level as well as for draining oil from reservoir, it is recommended that the reservoir is checked and serviced regularly.

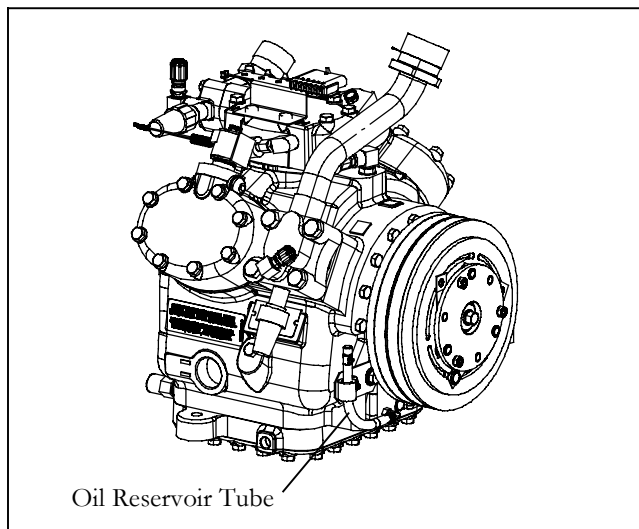

Figure 4-12. Compressor Service Connections

4.14.2 Refrigerant Removal From An Inoperative Compressor.

To remove the refrigerant from a compressor that is not operational, do the following:

- a. Attach a manifold gauge set as shown in Figure 4-13 and isolate the compressor by front seating the suction and discharge valves.
- b. Recover refrigerant with a refrigerant reclaimer. If the discharge service valve port is not accessible, it will be necessary to recover refrigerant through the suction service valve port only.
- c. Service or replace components as required and leak check the compressor.
- d. Using refrigerant hoses designed for vacuum service, connect a vacuum pump to center connection of manifold gauge set. Evacuate system to 500 microns. Close off pump valve, isolate vacuum gauge and stop pump. Wait 5 minutes to verify that vacuum remains at or below 1000 microns.
- e. Once vacuum is maintained, backseat compressor service valves and disconnect manifold gauge set.
- f. Check refrigerant level. Refer to paragraph 4.7. It may be necessary to clear any alarms that have been generated.

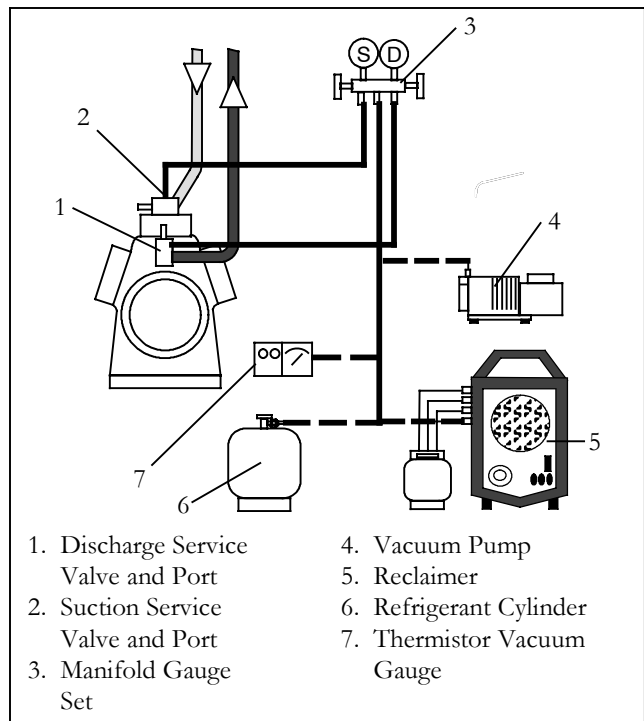

Figure 4-13. Compressor Service Connections

4.14.3 Pump Down An Operable Compressor For Repair

To service an operable compressor, pump the refrigerant into the condenser coil and receiver as follows:

- a. Install manifold gauge set. Refer to Figure 4-13.
- b. Frontseat the compressor suction service valve by turning clockwise.
- c. Install a jumper on the compressor mounted low pressure switch. Start the unit and run in cooling until 10 " /hg (25.4 cm/hg) of vacuum is reached. Shut the system down and tag out system power source.
- d. Frontseat the compressor discharge service valve and wait 5 minutes to verify that vacuum is maintained. If the pressure rises above vacuum, open the compressor discharge service valve and repeat steps c and d until a vacuum is maintained.
- e. Service or replace components as required and leak check the compressor.
- f. Using refrigerant hoses designed for vacuum service, connect a vacuum pump to the center connection of the manifold gauge set. Evacuate system to 500 microns. Close off pump valve, isolate vacuum gauge and stop pump. Wait 5 minutes to verify that vacuum remains at or below 1000 microns.

- g. Once vacuum is maintained, re-connect low pressure switch. Backseat compressor service valves and disconnect manifold gauge set.
- h. Check refrigerant level. Refer to paragraph 4.7. It may be necessary to clear any alarms that have been generated.

4.14.4 Removing the Compressor

If compressor is inoperative and the unit still has refrigerant pressure, isolate the compressor and remove the refrigerant. Refer to paragraph 4.14.2. If compressor is operative, perform a pump down. Refer to paragraph 4.14.3.

- a. Place main battery disconnect switch in OFF position and lock.
- b. Tag and disconnect wiring to the high pressure and low pressure switch, unloaders and clutch.
- c. Remove tension on drive belts, remove drive belts.
- d. Loosen bolts at suction and discharge service valve flanges and break seal to be sure pressure is released. Remove bolts.
- e. Remove four bolts holding compressor to base
- f. Attach sling or other device to the compressor and remove compressor from the coach through the access door.

NOTES

1. Service replacement compressors are sold without service valves. Valve pads are installed in their place. The optional unloaders are not supplied, as the cylinder heads are shipped with plugs. The customer should retain the original unloader valves for use on the replacement compressor.
2. The piston plug that is removed from the replacement compressor head must be installed in the failed compressor if returning for warranty or core credit.
3. Do not interchange allen-head capscrews that mount the piston plug and unloader, they are not interchangeable.
4. Check oil level in service replacement compressor. (Refer to paragraphs 1.3 and 4.14.6.)

- g. Remove the three socket head capscrews from the cylinder head(s) that have unloader valves installed. See Figure 4-15. Remove the unloader valve and bypass piston assembly, keeping the same capscrews with the assembly. The original unloader valve must be transferred to the replacement compressor. The plug arrangement removed from the replacement is installed in the original compressor as a seal. If piston is stuck, it may be extracted by threading a socket head capscrew into top of piston. A small Teflon seat ring at the bottom of the bypass piston plug must be removed.

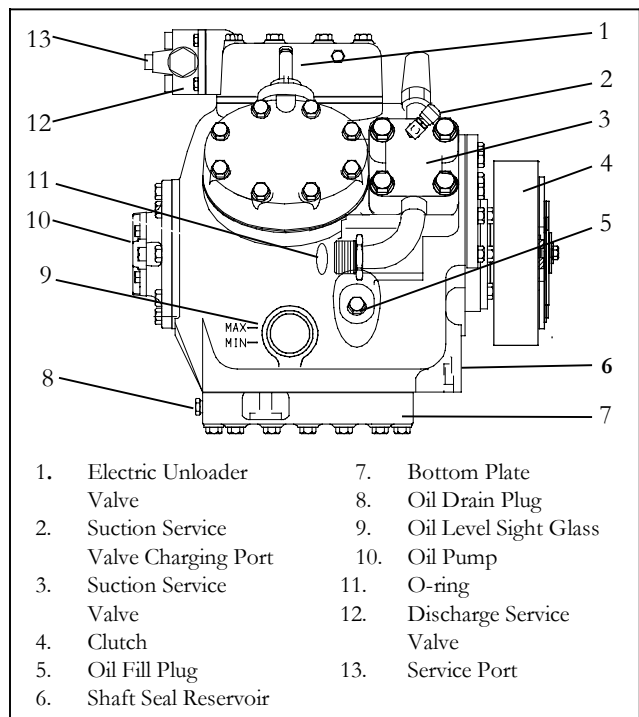

Figure 4-14. Compressors

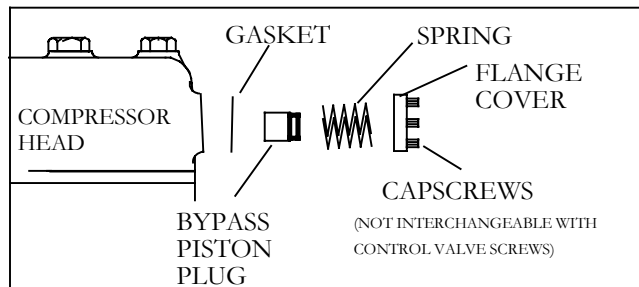

Figure 4-15. Removing Bypass Piston Plug

- h. Remove the pressure switches and install on replacement compressor after checking switch operation (refer to paragraph 4.9).
- i. Remove clutch assemble and retain original clutch key. Install on replacement compressor.

- j. Install compressor in unit by performing the removal steps in reverse. It is recommended that new locknuts be used when replacing compressor. Install new gaskets on service valves and tighten bolts uniformly (55 to 80 ft-lbs suction and 20 to 30 ft-lbs discharge service valves).
- k. Leak check connections and replace filter-drier.
- l. Using refrigerant hoses designed for vacuum service, connect a vacuum pump (see Figure 4-13) and evacuate compressor to 500 microns.
- m. Open compressor service valves.
- n. Start unit and check refrigerant level (refer to paragraph 4.7).
- o. Check compressor oil level (refer to paragraph 4.14.6). Add or remove oil if necessary.
- p. Check compressor unloader operation.(refer to paragraph 4.14.7)
- q. Backseat compressor service valves.
- r. Remove manifold gauge set (refer to paragraph 4.4.1).

4.14.5 Transferring Compressor Clutch

To remove a clutch (see Figure 4-16) from a compressor and install on a replacement compressor, do the following:

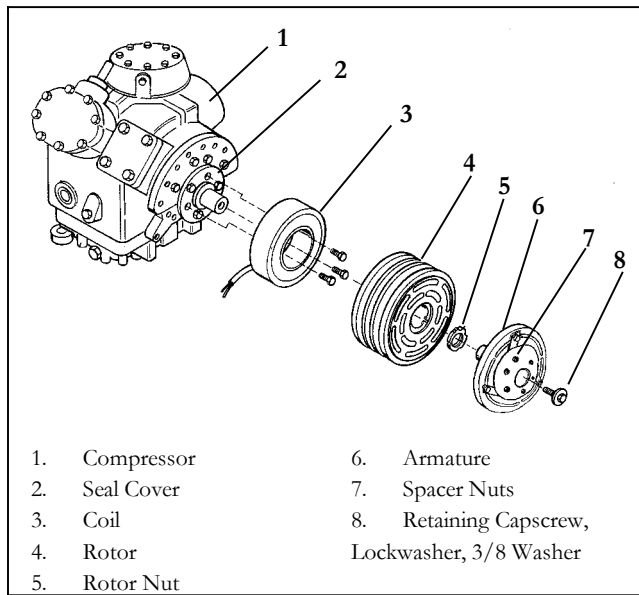

Figure 4-16. Compressor Clutch

- a. Place main battery disconnect switch in OFF position and lock.
- b. Tag and disconnect wiring to the clutch.

- c. Remove tension on drive belts, remove drive belts.
- d. Remove the armature as a complete assembly by removing the retaining capscrew, lockwasher, and special 3/8 washer from the compressor crankshaft. Use spanner wrench to prevent crankshaft rotation.
- e. Install a 7/8-14 x 4” (MCC P/N 07-00381-00) capscrew into the center hole of the armature assembly and use it as a jacking bolt to remove the armature. Use spanner wrench as in step d. to prevent crankshaft rotation.
- f.Using special tool (MCC P/N 07-00242-01), remove the rotor nut and rotor. Retain original key.
- g. Noting the position of the wire, remove the three bolts holding the coil to the compressor.
- h. Remove every other bolt from the seal cover of the new compressor in the same manner as the original compressor. Mount the coil assembly with the wire in the same orientation as it was mounted on the original compressor. Tighten the mounting bolts to 45-50 ft/lbs (5.53-6.92 mkg).
- i. Mount the rotor on the shaft. Seat the rotor to the hub, using the rotor nut. Be sure pulley turns freely without binding. Tighten rotor nut by first noting torque necessary to start the nut on the hub and then adding 50 ft/lbs (6.92 mkg) of torque.

4.14.5.a 3-Point Shim-less Compressor Clutch

- a. Install armature on shaft using original key and tighten mounting bolt to 20 ft/lbs (2.8 mkg).
- b. Perform a check of the air gap between the inside face of the armature and the mating face of the rotor. The air gap should be measured with a minimum of 50 psig (3.44 bar) in the crankcase. A preliminary check may be performed before the crankcase is pressurized but a final check must be performed before the clutch is operated. The gap should be between 0.030 and 0.060 inch (7.62 to 15.24 mm).
- c. Loosen each of the three lock-nuts with a 7/16” box wrench while holding the jacking screws with a 1/8” hex socket wrench.
- d.Back off the three jacking screws until they do not touch the armature plate.
- e. Turn the jacking screws clock-wise until they make contact with the armature plate and then one and one half more turns after contact.
- f. Measure the initial clearance, the gap should be between .030” and .060”. All three set screw locations should be very close in clearance dimensions.



- g. With the clearance set, hold each set screw while tightening the lock nuts to 7 ft/lbs.
- h. Reconnect wiring and test clutch operation.

4.14.6 Compressor Oil Level

To check, and if required correct, the compressor oil level do the following:

- a. Operate the coach for at least one-half hour at fast idle speed, with the temperature controls at the coolest setting, and the compressor fully loaded. It may be necessary to pre-heat the coach and/or operate the system in the reheat mode to keep the compressor fully loaded throughout this procedure
- b. Ensure the system is fully charged (refer to paragraph 4.7) and the compressor crankcase is warm to the touch after fifteen minutes of operation.
- c. Shut off the system and immediately record the oil level in the compressor sight glass. See Figure 4-14. If the compressor is not level, an average between the sight glass levels will have to be made to determine level.
- d. The correct oil level for this application should be between the Min/Max of the oil level sightglass. See Figure 4-14. If the oil level is correct, release the coach into service. If the level is above the sightglass maximum, proceed to step e. If the level is below the sightglass minimum proceed to step f.
- e. To remove oil and bring the level between the Min/Max sightglass markings, do the following:
 - 1. With the system off, connect a manifold gauge set to the compressor suction and discharge service valves. Front seat the service valves to isolate the compressor from the system (See Figure 4-13) and reclaim the refrigerant to below atmospheric pressure. Shut off the reclaimer and verify the pressure does not rise. If the pressure rises, continue reclaiming until the pressure remains below atmospheric.



WARNING

Extreme care must be taken to ensure that all the refrigerant has been removed from the compressor crankcase or the resultant pressure will forcibly discharge compressor oil.

- 2. Drain or pump out compressor oil until the level is brought between the Min/Max markings.
- 3. Evacuate the compressor to 500 microns. Backseat the compressor service valves and repeat the oil level check procedure.
- f. To add oil to the compressor, do the following:
 - 1. With the system off, connect a manifold gauge set to the compressor suction and discharge service valves. Front seat both service valves to isolate the compressor from the system (See Figure 4-13) and reclaim the refrigerant to below atmospheric pressure. Shut off the reclaimer and verify the pressure does not rise. If the pressure rises, continue reclaiming until the pressure remains below atmospheric.
 - 2. Add oil to compressor crankcase slowly, through the oil fill plug opening (see Figure 4-14) to bring level to mid range of allowed levels.
 - 3. Evacuate compressor to 500 microns. Backseat compressor suction and discharge valves, start system and recheck oil level.
 - 4. Remove manifold gauge set.

4.14.7 Checking Unloader Operation

To check unloader operation do the following:

- a. Install a manifold gauge set as shown in Figure 4-13. Ensure both manifold valves are frontseated and center connection is tight on blank fitting.
- b. Midseat compressor suction service valve.
- c. Disconnect the suction pressure transducer. This will force the controller to energize the unloader(s).
- d. Start the bus and run in cooling, lower set point if required to ensure system remains in full speed cooling.
- e. Locate the unloader connector at the compressor. Observe manifold suction gauge while unplugging the connector. Pressure should decrease 3 to 5 psi (0.2 to 0.4 bar) when the unloader is unplugged and increase the same amount as the plug is reconnected. Repeat test for second unloader if fitted.



Mobile Climate Control

- f. If pressures do not react as described, check unloader coil or repair unloader mechanism as required.
- g. When testing is complete, reconnect transducer and unloader connectors and remove manifold gauge set.
- h. Disconnection of the suction pressure transducer will cause an alarm. Once the transducer is reconnected, the alarm will go to inactive and can then be cleared.

4.15 TEMPERATURE SENSOR CHECKOUT

- An accurate ohmmeter must be used to check resistance values shown in Table 4-1.
- Due to variations and inaccuracies in ohmmeters, thermometers or other test equipment, a reading within two percent of the chart value would be considered acceptable. If a sensor is bad, the resistance value would usually be much higher or lower than the value given in Table 4-1.
- At least one sensor lead must be disconnected from the controller before any reading can be taken. Not doing so will result in a false reading. Two preferred methods of determining the actual test temperature at the sensor are an ice bath at 32°F (0°C) and/or a calibrated digital temperature meter.

Table 4-1 Temperature Sensor Resistance

Temperature		Resistance In Ohms
°F	°C	
-20	-28.9	165,300
-10	-23.3	117,800
0	-17.8	85,500
10	-12.2	62,400
20	- 6.7	46,300
30	- 1.1	34,500
32	0	32,700
40	4.4	26,200
50	10.0	19,900
60	15.6	15,300
70	21.1	11,900
77	25	10,000
80	26.7	9,300
90	32.2	7,300
100	37.8	5,800
110	43.3	4,700
120	48.9	3,800

4.16 PRESSURE TRANSDUCER CHECKOUT

NOTE

System must be operating to check transducers.

- With the system running use the driver display and manifold gauges to check suction and/or discharge pressure(s) simultaneously.

- Determine with the gauges whether one or both pressure readouts are correct. If one is correct, exchange the pressure transducer locations. If the problem moves with the transducer, replace the faulty transducer.
- If the driver display read out disagrees with both values shown on the manifold gauges proceed to step d.
- Verify that the wiring to the transducer(s) is in good condition.
- Use a digital volt-ohmmeter to measure voltage across the transducer connector corresponding to terminals A & B. See Figure 4-17. The reading should be 5.0 VDC.
- Use a digital volt-ohmmeter to measure voltage across the transducer at terminals A & C. See Figure 4-17. Compare to values in Table 4-2. A reading within two percent of the values in the table would be considered good.

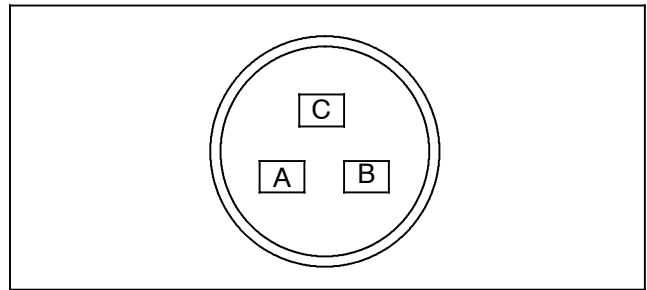

Figure 4-17 Transducer Terminal Location

4.17 REPLACING SENSORS AND TRANSDUCERS

- Place main battery disconnect switch in OFF position and lock.
- Tag and disconnect wiring from defective sensor or transducer.
- Remove and replace defective sensor or transducer. Sensor/transducer connections are fitted with Schreder valves to facilitate replacement.
- Connect wiring to replacement sensor or transducer.
- Checkout replacement sensor or transducer. Refer to section 4.15 or 4.16 as applicable.
- Repair or replace any defective component(s), as required.

Table 4-2 Pressure Transducer Voltage

"/hg	Voltage	Psig	Voltage	Psig	Voltage	Psig	Voltage	Psig	Voltage	Psig	Voltage
20"	0.369	40	0.858	95	1.397	150	1.936	205	2.475	260	3.014
10"	0.417	45	0.907	100	1.446	155	1.985	210	2.524	265	3.063
Psig	Voltage	50	0.956	105	1.495	160	2.034	215	2.573	270	3.112
0	0.466	55	1.007	110	1.544	165	2.083	220	2.622	275	3.161
5	0.515	60	1.054	115	1.593	170	2.132	225	2.671	280	3.210
10	0.564	65	1.103	120	1.642	175	2.181	230	2.720	285	3.259
15	0.614	70	1.152	125	1.691	180	2.230	235	2.769	290	3.308
20	0.663	75	1.204	130	1.740	185	2.279	240	2.818	295	3.357
25	0.712	80	1.250	135	1.789	190	2.328	245	2.867	300	2.406
30	0.761	85	1.299	140	1.838	195	2.377	250	2.916	305	3.455
35	0.810	90	1.348	145	1.887	200	2.426	255	2.965	310	3.504

Table 4-3 R-134a Temperature - Pressure Chart

Temperature		Vacuum		
°F	°C	"/hg	Kg/cm ²	Bar
-40	-40	14.6	37.08	0.49
.35	.37	12.3	31.25	0.42
-30	-34	9.7	24.64	0.33
-25	-32	6.7	17.00	0.23
-20	-29	3.5	8.89	0.12
-18	-28	2.1	5.33	0.07
-16	-27	0.6	1.52	0.02

Temperature		Pressure		
°F	°C	Psig	Kg/cm ²	Bar
-14	-26	0.4	0.03	0.03
-12	-24	1.2	0.08	0.08
-10	-23	2.0	0.14	0.14
-8	-22	2.9	0.20	0.20
-6	-21	3.7	0.26	0.26
-4	-20	4.6	0.32	0.32
-2	-19	5.6	0.39	0.39
0	-18	6.5	0.46	0.45
2	-17	7.6	0.53	0.52
4	-16	8.6	0.60	0.59
6	-14	9.7	0.68	0.67
8	-13	10.8	0.76	0.74
10	-12	12.0	0.84	0.83
12	-11	13.2	0.93	0.91
14	-10	14.5	1.02	1.00
16	-9	15.8	1.11	1.09
18	-8	17.1	1.20	1.18
20	-7	18.5	1.30	1.28
22	-6	19.9	1.40	1.37
24	-4	21.4	1.50	1.48
26	-3	22.9	1.61	1.58

Temperature		Pressure		
°F	°C	Psig	Kg/cm ²	Bar
28	-2	24.5	1.72	1.69
30	-1	26.1	1.84	1.80
32	0	27.8	1.95	1.92
34	1	29.6	2.08	2.04
36	2	31.3	2.20	2.16
38	3	33.2	2.33	2.29
40	4	35.1	2.47	2.42
45	7	40.1	2.82	2.76
50	10	45.5	3.20	3.14
55	13	51.2	3.60	3.53
60	16	57.4	4.04	3.96
65	18	64.1	4.51	4.42
70	21	71.1	5.00	4.90
75	24	78.7	5.53	5.43
80	27	86.7	6.10	5.98
85	29	95.3	6.70	6.57
90	32	104.3	7.33	7.19
95	35	114.0	8.01	7.86
100	38	124.2	8.73	8.56
105	41	135.0	9.49	9.31
110	43	146.4	10.29	10.09
115	46	158.4	11.14	10.92
120	49	171.2	12.04	11.80
125	52	184.6	12.98	12.73
130	54	198.7	13.97	13.70
135	57	213.6	15.02	14.73
140	60	229.2	16.11	15.80
145	63	245.6	17.27	16.93
150	66	262.9	18.48	18.13
155	68	281.1	19.76	19.37

SECTION 5

ELECTRICAL

5.1 INTRODUCTION

This section includes electrical wiring schematics. The schematics shown in this section provides information for the 50-2104 model rooftop air conditioning units which are fitted with two evaporator blower/motor assemblies in each

evaporator section, and four (4) condenser fan motor assemblies. Figure 5-1 shows the MCC schematic used with the 50-2104 system.

Additional technical data regarding wiring, electrical connectors and relay assignment are listed below .

UNIT	CONTROLLER	FIGURE NUMBERS
50-2104	MCC	Figure 5-1

NOTES:

- WIRING HARNESS SUPPLIED BY NEWFLYER
- POWER CABLE SUPPLIED BY NEWFLYER
- TWISTED PAIR CABLE (>4 TWISTS/FOOT)
- SHIELDED TWISTED CABLES

* MAIN DC CIRCUIT BREAKERS SHOULD BE EQUIVALENT TO ETA 8340 SERIES. THE TRIP CURVE SHOULD BE SIMILAR TO M1 MEDIUM DELAY CURVE.

* ON BODY POWER CIRCUITS, THE MAXIMUM VOLTAGE DROP TO HVAC UNIT SHOULD BE LESS THAN 0.5VDC (INCLUDES POWER AND GROUND CIRCUITS). DEPENDING ON THE CABLE LENGTH AND CURRENT DRAW RATING, PROPER SIZE CABLE NEED TO BE SELECTED.

ELECTRICAL CONNECTION:

- A - 19-WAY DEUTSCH CONNECTOR (HDP)
MCC SIDE: HDP24-24-19PN (PIN TERMINAL)
NF SIDE: HDP26-24-19SN (SOC TERMINAL)
- B - 3-WAY DEUTSCH CONNECTOR (DT)
MCC SIDE: DT04-3P-L012 (PIN TERMINAL)
NF SIDE: DT06-3S (SOC TERMINAL)
- C - 6-WAY PACKARD CONNECTOR (WEATHER)
MCC SIDE: 12010975 (MALE TERMINAL)
NF SIDE: 12015799 (FEMALE TERMINAL)
- D - 10-WAY AMP MICRO MATE_N_LOK
RECEPTACLE: 1-794617-0 (PLUG INTO DISPLAY)
PLUG CONN: 1-794616-0 (MATING TO REC ONE)

ELECTRICAL WIRING SPEC.:

- WIRE #A: 4GA RED WIRE
- WIRE #B,C: 10GA RED WIRE
- WIRE #D,E: 10GA BLACK WIRE
- WIRE #FP1-4: 14GA WHITE GXL WIRE
- WIRE #FG1-4: 14GA WHITE GXL WIRE
- WIRE #1 -#20: 14GA WHITE GXL WIRE
- WIRE #31-#99: 18GA WHITE TXL WIRE
- WIRE CAN+,-: 18GA WHITE TXL WIRE

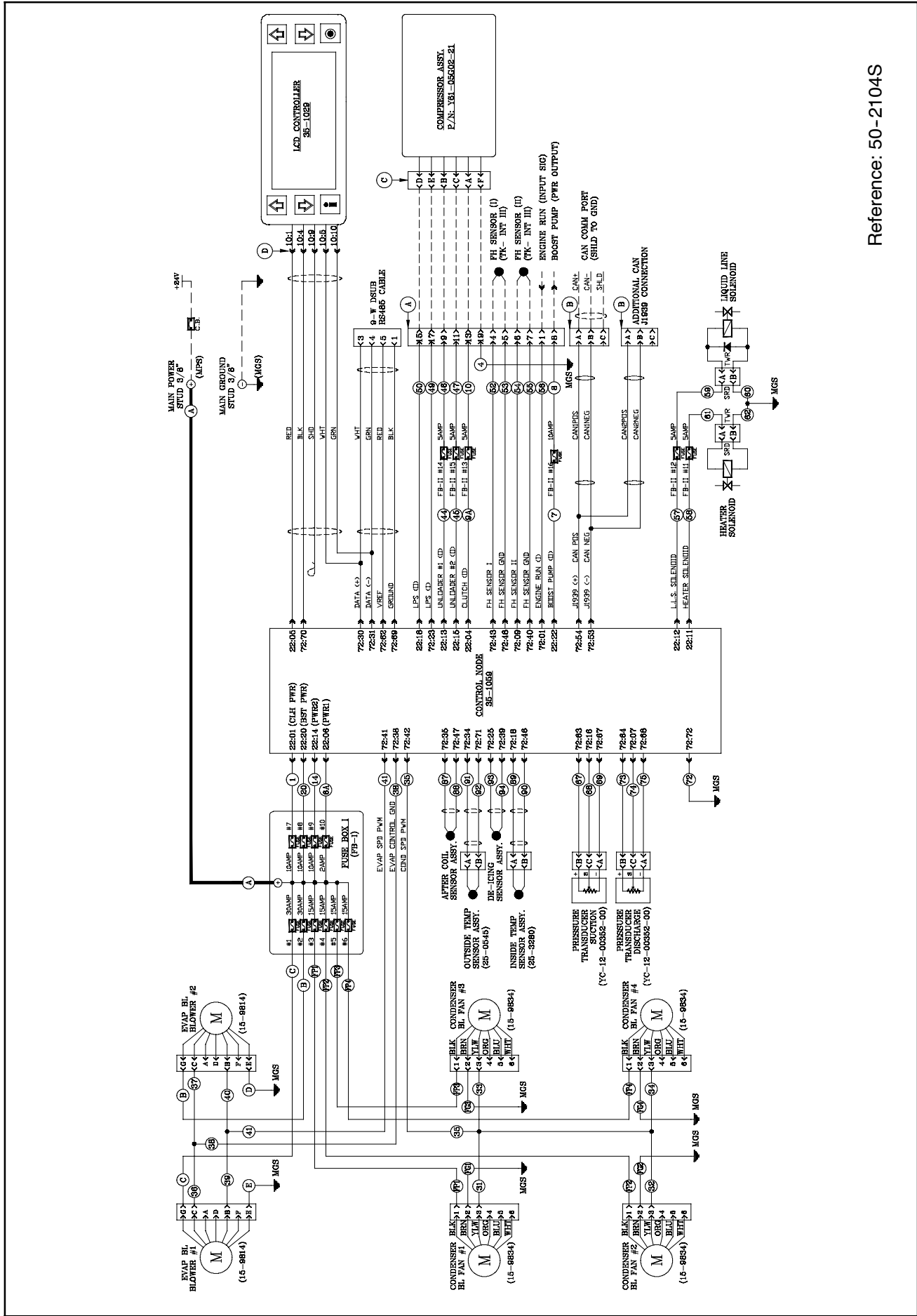

Reference: 50-2104S

Figure 5-1 SCHEMATIC

INDEX

A

Air Filter 4-15

C

Circuit Breaker 1-4
 Clutch 4-18
 Compressor 1-3, 4-16, 4-17
 Condenser Fan 1-3
 Condensing Section 1-2

D

DESCRIPTION 1-1

E

ELECTRICAL 5-1
 Evacuation 4-7
 Evacuation, One Time 4-8
 Evacuation, Triple 4-8
 Evaporator 1-3
 Evaporator Fan 1-3

F

Filter-Drier 4-12
 Fuse 1-4

H

Heating Cycle 1-5
 High Pressure Switch 1-2, 1-3, 1-4, 4-11

L

LEAK CHECK 4-7

Low Pressure Switch 1-3, 1-4, 4-11

M

Maintenance Schedule 4-1

O

Oil Level 4-19
 Operating Instructions 2-1
 OPERATION 2-1

P

Pressure Transducer 4-21
 Pump Down 4-6, 4-16

R

Refrigerant Charge 1-3, 4-8, 4-9, 4-11
 Refrigerant Removal 4-7, 4-16
 Refrigeration Cycle 1-5
 Rooftop Unit 1-2

S

SAFETY Safety-1
 SERVICE 4-1
 Service Valves 4-3
 Shaft Seal Reservoir 4-16
 Starting 2-1
 Stopping 2-1
 Superheat 4-14

T

Temperature Pressure Chart 4-23
 Temperature Sensor 1-3, 4-21
 Thermostatic Expansion Valve 1-3, 4-14



INDEX

Top Cover 4-2
TROUBLESHOOTING 3-1

W

Water Temperature Switch 1-3

Every driver deserves the best possible vehicle climate with MCC products

MCC provides exceptional performance in mobile climate comfort.



www.mcc-hvac.com

Member of MCC Group • Certified ISO 9001 and ISO 1 4001.
Specifications subject to change without notice. MCC is a registered trademark.